

MODELS WM 8A-3 and 14A-3

WM 8A-3 and 14A-3 PART LIST

REF NO.	PART NUMBER	DESCRIPTION	WM 8A-3	WM 14A-3
1	10-14228-31-XXX	Projector	X	X
2	10-03227-40-560	Projector Gasket (2 each)	X	X
3	16-42252-16-550	Projector Nipple (included in item 5)	X	X
4	60-26229-51-550	Regulator Assembly*	X	X
4a	60-08050-51-550	Diaphragm Repair Kit* (for item 4)	X	X
4b	60-14202-51-550	Valve Stem Assembly* (included in item 4)	X	X
5	60-26390-51-550	Projector Supply Line	X	X
6	60-15889-51-550	Valve to Chiller Supply Line	X	X
7	10-14532-51-550	Valve Bracket	X	X
8	60-14511-51-550	Push Button Stem Assembly*	X	X
9	10-14523-31-870	Stem Bushing	X	X
10	40-26741-43-730	Lever Arm for Push Button Assembly	X	X
11	10-06876-08-640	Glass Filler Plug Button	X	X
12	16-02705-08-XXX	Strainer Plate (included in item 15)	X	X
13	10-26399-31-XXX	Drain Plug (included in item 15)	X	X
14	10-01471-40-560	Waste Gasket	X	X
15	60-27032-51-550	Precooler Assembly (includes items 12 and 13)	X	X
16	10-14514-31-550	Precooler Baffle	X	X
17	60-15489-51-550	Evaporator Chiller	X	
17	60-15528-51-550	Evaporator Chiller		X
18	19-42339-51-550	Temperature Control	X	X
19	60-26797-51-550	Compressor Assembly	X	
19	60-26793-51-550	Compressor Assembly		X
19a	19-26922-82-550	Overload/Relay Assembly (included in item 19)	X	
19a	19-26926-82-550	Overload/Relay Assembly (included in item 19)		X
20	10-10800-51-010	Drier	X	X
21	19-14761-51-550	Fan Motor	X	X
22	SEE FAN NOTE**	Fan Blade**	X	X
23	40-26720-43-730	Fan Bracket	X	X
24	10-14528-43-730	Shroud	X	X
25	19-15079-51-550	Condenser	X	
25	19-15080-51-550	Condenser		X
26	17-14548-42-XXX	Receptor	X	X
27	11-26275-43-XXX	Receptor Screws (4 each)	X	X
28	40-06609-43-730	Hanger Bracket (not shown)	X	X
29	40-14322-43-XXX	Front Panel (not shown)	X	X
30	40-14839-43-XXX	Left Side Panel	X	X
31	40-14840-43-XXX	Right Side Panel	X	X
32	10-15431-51-550	Back Bumper (2 each)	X	X
33	11-10083-43-890	Panel Screws (18 each) (not shown)	X	X
34	40-15077-43-730	Shelf	X	X
35	40-26030-43-730	Base	X	X
36	13-14905-31-920	Name Plate (not shown)	X	X
37	40-14748-43-730	Tie Bar	X	X
38	10-14551-31-550	Side Frames	X	X
39	19-26679-51-550	Wiring Assembly	X	X
40	29-26871-16-550	Capillary Tube	X	
40	29-14859-16-550	Capillary Tube		X
41	40-15452-16-550	Inlet Supply Line	X	X

ACCESSORIES AVAILABLE

Glass Fillers - See Spec Book

Glass Filler Installation Kit - 73-26285-51-550 (Does not include Glass Filler)

Vandal Proof Kit - 73-15243-51-640*

Water Filtration Kit - 73-15242-51-550* (mounts external to cooler)

73-15423-51-550* (installs inside cooler)

XXX Please specify color when ordering. See Color Chart on page I-A for colors available.

*See Detailed Parts Section for further breakdown.

** FAN NOTE: If the current fan blade screws on, use the 10-42095-43-730. If it does not screw on, use the 10-42343-43-730

MODELS WM 8A-3 and 14A-3

MODEL#	MFG DATE S/N ENDING	COLD WATER CAP*	COMP H/P	VOLTAGE ± 10	PH	HZ	TOTAL AMPS	R-12 REFRIG CHARGE*	WATER INLET PSIG
WM8A-3	H88 —	8GPH	1/6	115	1	60	3.0	6.0	20-90
WM14A-3	H88 —	14GPH	1/4	115	1	60	5.8	7.4	20-90

HEIGHT: 28"

WIDTH: 18 1/8"

DEPTH: 14 1/4"

*ARI ratings: capacity at GPH cooled to 50° with 90°F ambient temperature and 80°F inlet water.

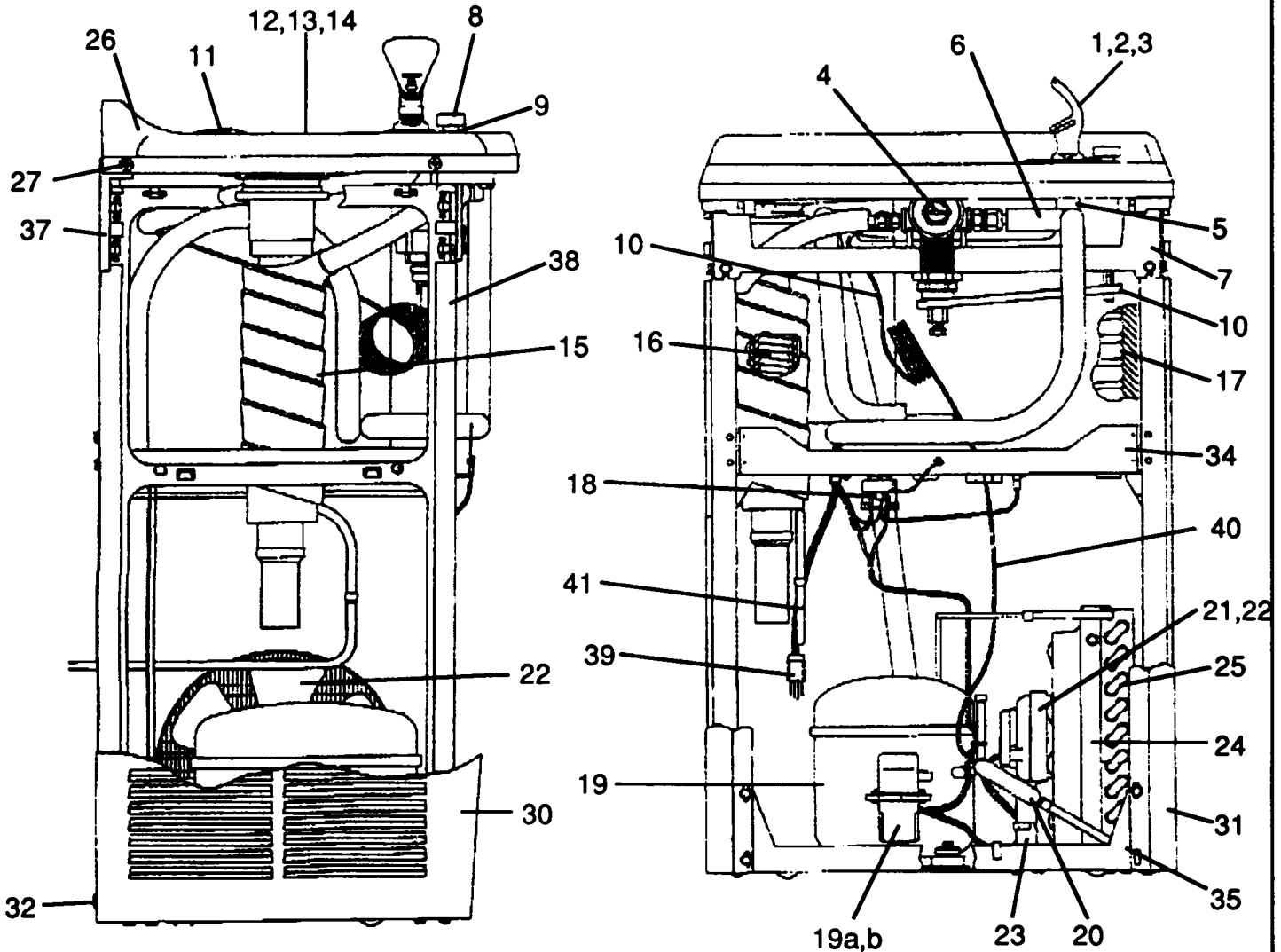

To order parts, contact your nearest Halsey Taylor wholesaler or representative.

Continued product improvement makes specifications subject to change without notice.

Halsey Taylor.