

# HALSEY TAYLOR OWNERS MANUAL

USES HFC-134A REFRIGERANT

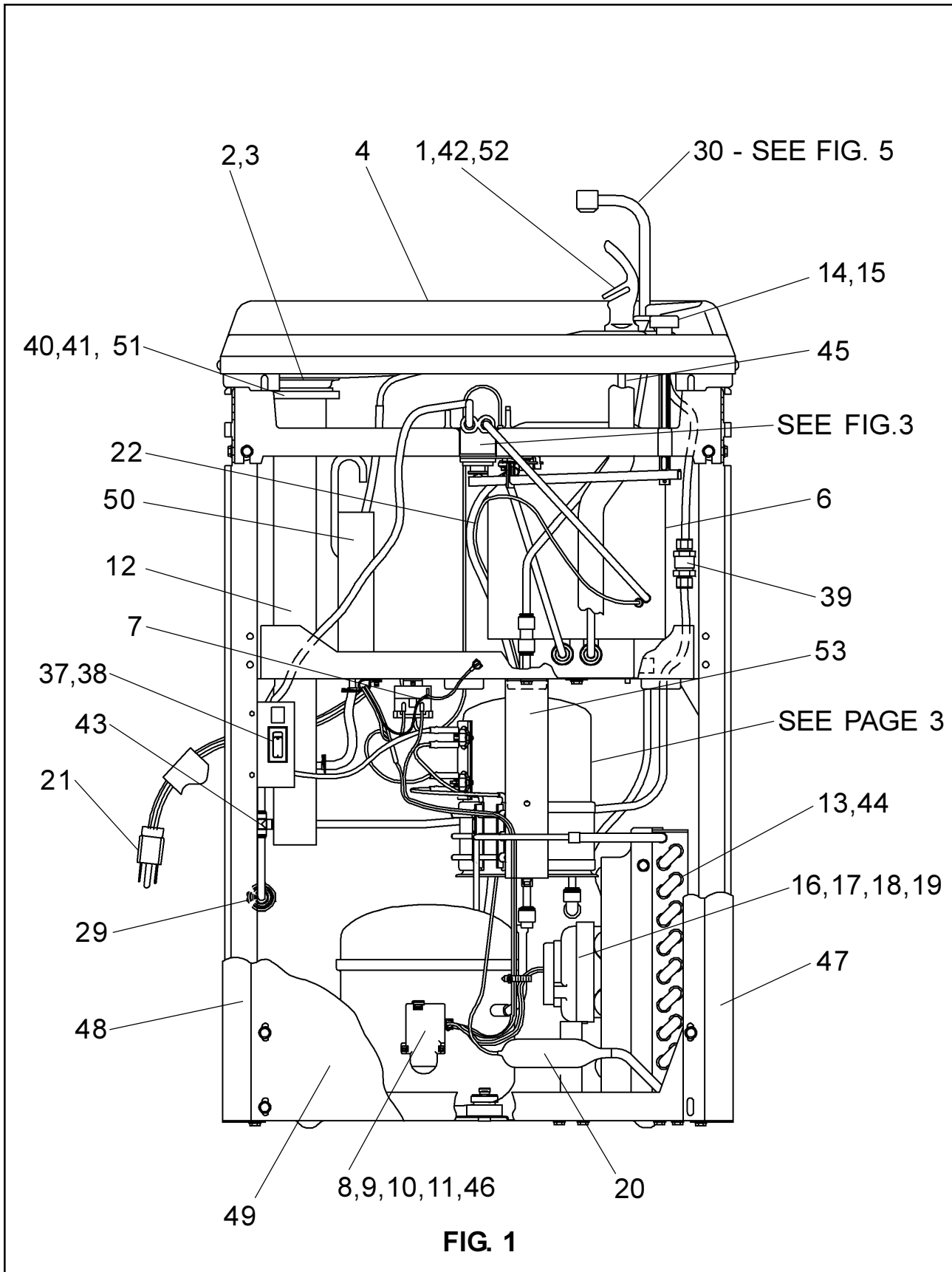

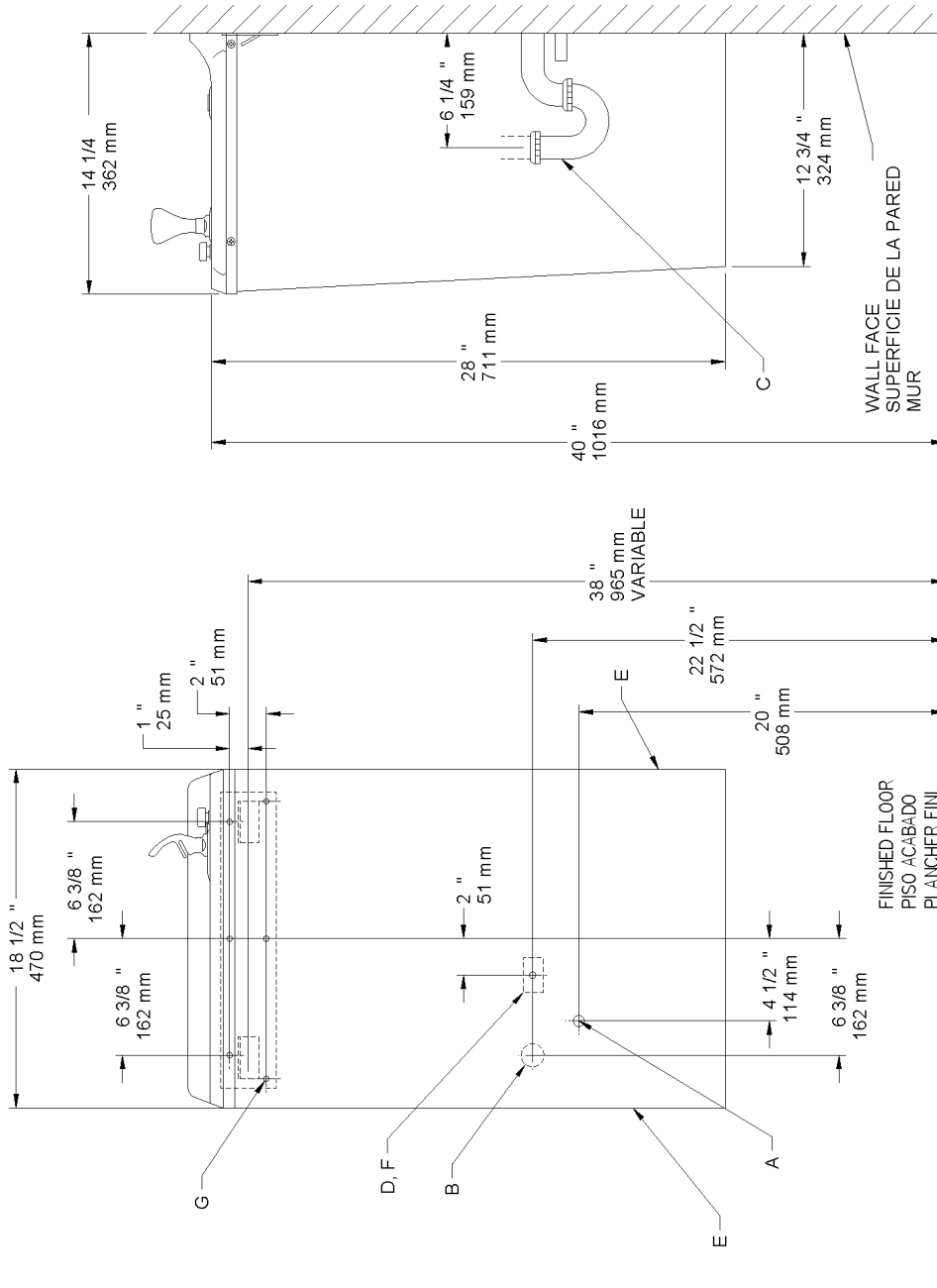

**FIG. 2**

**LEGEND/LEYENDA/LÉGENDE**

**A = RECOMMENDED WATER SUPPLY LOCATION 3/8 O.D. UNPLATED COPPER TUBE CONNECT STUB OUT 1-1/2 IN. (38mm) FROM WALL SHUT OFF BY OTHERS**  
 SE RECOMIENDA UBICAR EL TUBO CORTO DE CONEXIÓN AL TUBO DE COBRE SIN CHAPAR DE 3/8" DE DIÁM. EXT. A 1-1/2" (38 mm) FUERA DE LA PARED DE LA LAVUE EN LA PARED COLOCADA POR TERCEROS.  
 EMPLACEMENT RECOMMANDÉ D'ALIMENTATION EN EAU PAR TUBE EN CUIVRE NON PLAQUÉ DE 3/8 PO. (9.5 mm) D.E. CONNECTANT UNE TUYAUTERIE DE 1-1/2 PO. (38 mm) DEPUIS LE ROBINET D'ARRÊT FOURNI PAR D'AUTRES.

**B = RECOMMENDED LOCATION FOR WASTE OUTLET 1-1/4" O.D. DRAIN**  
 UBICACIÓN RECOMENDADA PARA EL DRENAJE DE SALIDA DE AGUA, DE 1 1/4" DE DIÁMETRO.  
 EMPLACEMENT RECOMMANDÉ POUR LE DRAIN DE 1-1/4" DE SORTIE D'EAU.

**C = 1-1/4 TRAP NOT FURNISHED**  
 PURGADOR DE 1 1/4 NO PROPORCIONADO  
 SIPHON 1-1/4 NON FOURNI

**D = ELECTRICAL OUTLET LOCATION**  
 UBICACIÓN DE LA TOMA DE ELECTRICIDAD  
 EMPLACEMENT DE LA PRISE DE COURANT

**E = INSURE PROPER VENTILATION BY MAINTAINING 4" (102mm) MIN. CLEARANCE FROM CABINET LOUVERS TO WALL.**  
 ASEGURE UNA VENTILACIÓN ADECUADA MANTENIENDO UN ESPACIO E 4" (102mm) MIN. DE HOLGURA ENTRE LA REJILLA DE VENTILACIÓN DEL MUEBLE Y LA PARED  
 ASSUREZ-VOUS UNE BONNE VENTILATION EN GARDANT 4" (102mm) MIN. ENTRE LES ÉVÉNEMENTS DE L'ENCEINTE ET LE MUR.

**F = POWER CORD 4' (1219mm) LONG**  
 CABLE ELÉCTRICO DE 4' (1219mm), DE LARGO  
 CORDON D'ALIMENTATION 4' (1219mm)

**G = 1/4" (6mm) SCREW HOLES IN MOUNTING PLATE**  
 AGUJEROS DE TORNILLO 1/4" (6mm) EN LA PLACA DE MONTAJE  
 TROUS DE VIS 1/4" (6mm) DANS LA PLAQUE DE MONTAGE

### SERVICING THE HOT TANK ASSEMBLY

1. The heating element must be fastened **TIGHTLY** to the tank (10 to 15 inch-lbs. of torque on the mounting screws). Failure to **TIGHTEN** heating element may cause rapid failure of the thermostat. Besure bottom edge of heating element is parallel with bottom flange of hot tank all around tank.

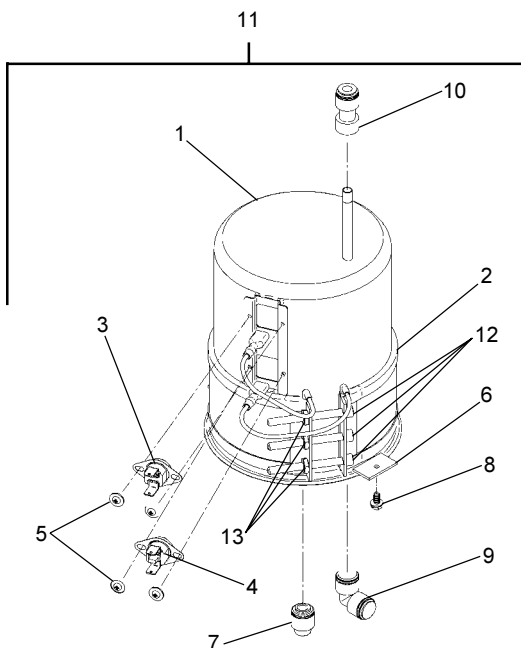

#### HOT TANK PARTS LIST

ITEM NO.	PART. NO.	DESCRIPTION
1	36116C	Hot Tank Weldment Assembly
2	36149C	Heating Element
3	36122C	Thermostat (L85-11)
4	36121C	Thermostat (98° C)
5	75610C	Screw - M3 Round Wash. Head
6	28310C	Hold Down Bracket
7	70606C	Drain Plug
8	70640C	Screw #8-18 x 5/16" HHTC
9	70793C	1/4 Elbow
10	70683C	1/4 Union
11	36129C	Hot Tank Assy
12	75607C	Screw - #8-32 x 2.00" PPHD
13	75655C	Nut -#8-32 Hex.

### PUSH BUTTON VALVE ADJUSTMENT

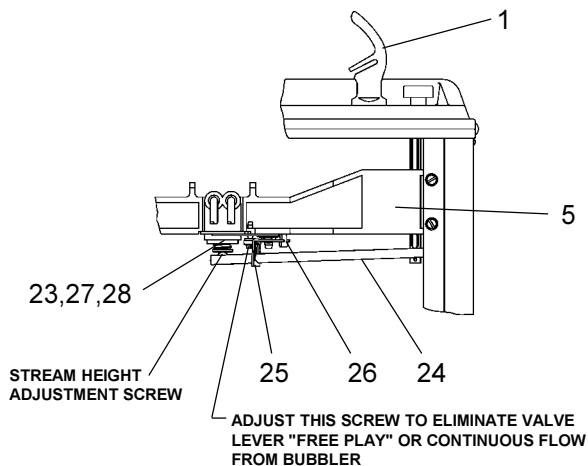
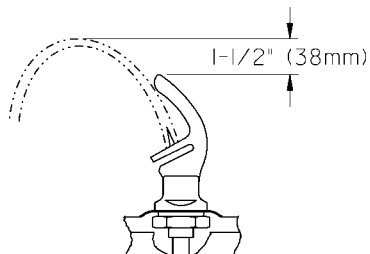

FIG. 3



CORRECT STREAM HEIGHT

FIG. 4

ITEMIZED PARTS LIST

ITEM NO.	PART NO.	DESCRIPTION
1	51544C	Bubbler
2	102639931640	Drain Plug
3	160270508640	Strainer Plate
4	401472642590	Basin
5	55860C	Bracket - Regulator Mounting
6	66506C	Evaporator (8 & 14 GPH)
7	31513C	Cold Control
*8	35762C	Compressor Serv. Pak (8 GPH)
	35775C	Compressor Serv. Pak (14 GPH)
9	36196C	Overload (8 GPH)
	35840C	Overload (14 GPH)
	35843C	Relay (14 GPH)
	36181C	Relay (8 GPH)
10	194243901550	Electrical Shield
11	35768C	Relay Cover (8 & 14 GPH)
12	45689C	Tailpipe Assy
13	66252C	Condenser (8 & 14GPH)
14	101453431640	Cap Push Button
15	101507531550	Push Button Stem
16	36144C	Fan Motor (8 GPH)
	31491C	Fan Motor (14 GPH)
17	104209543730	Fan Blade (8 GPH)
	30664C	Fan Blade (14 GPH)
18	70018C	Fan Blade Nut
19	402672043730	Fan Motor Bracket
20	66202C	Drier (8 GPH)
	66203C	Drier (14 GPH)
21	36137C	Power Cord
22	66229C	Heat Exchanger (8 GPH)
	66257C	Heat Exchanger (14 GPH)
23	15005C	Regulator Retaining Nut
24	26860C	Regulator Lever
25	26861C	Pivot Bracket
26	26862C	Regulator Retaining Bracket
27	50986C	Regulator Holder
28	61314C	Regulator
29	55996C	Strainer
30	45786C	Hot Valve
31	33659000	Gasket - Body
32	40596C	Shroud
33	40597C	Gooseneck
34	51543C	Lever Handle
35	70921C	Mounting Nut
36	92712C	Stem Assy
37	28427C	Hot Tank Switch Bracket
38	36101C	Hot Tank Switch
39	55832C	Flow Regulator Assy
40	75588C	Nut - Slip Joint 1-1/4
41	55913C	Adaptor - Drain
42	56159C	Nipple - Bubbler
43	70682C	Tee - 1/4
44	101452831560	Fan Shroud (14 GPH)
45	56092C	Poly Tubing (Cut To Length)
46	35844C	Capacitor (14 GPH)
47	See Color Table	Panel - Side Right
48	See Color Table	Panel - Side Left
49	See Color Table	Panel - Front
50	45670C	Vacuum Break Assy
51	100147140560	Drain Gasket
52	100322740560	Bubbler Gasket
53	22588C	Hot Tank Mounting Bracket
NS	400660943730	Hanger Bracket

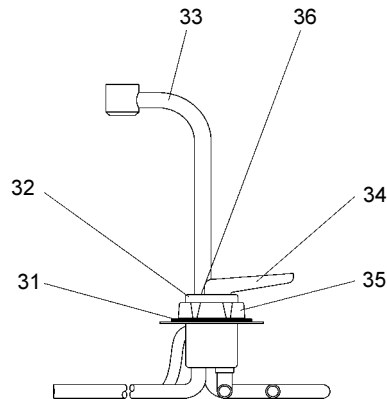
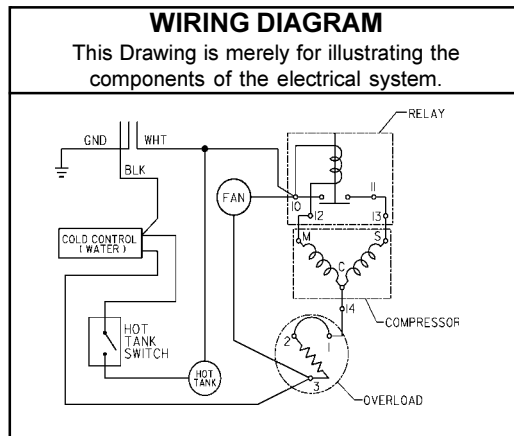

FIG. 5

\*INCLUDES RELAY & OVERLOAD. IF UNDER WARRANTY, REPLACE WITH SAME COMPRESSOR USED IN ORIGINAL ASSEMBLY. NOTE: All correspondence pertaining to any of the above water coolers or orders for repair parts MUST include Model No. and Serial No. of cooler, name and part number of replacement part.

COLOR	RIGHT PANEL ITEM 47	LEFT PANEL ITEM 48	FRONT PANEL ITEM 49
Platinum (PV)	401484048410	401483948410	401432248410
Almond (AV)	26879C	26878C	26874C
Slate (SV)	401484048440	401483948440	401432248440
Stainless Steel (SS)	401484042830	401483942830	401432242830

**Halsey Taylor**  
2222 CAMDEN COURT  
OAKBROOK, IL 60523