

MODEL XP16W-1

XP16W-1 PARTS LIST

| REF NO | PART NUMBER | DESCRIPTION |
|--------|-----------------|-------------------------------------|
| 1 | 10-14228-31-640 | Projector |
| 2 | 10-14224-31-550 | Projector Nipple |
| 3 | 10-03227-40-560 | Gasket (2 each) |
| 4 | 60-26855-51-550 | Regulator Assembly* |
| 4a | 60-08050-51-550 | Valve Repair Kit (for item 4)* |
| 4b | 60-14202-51-550 | Stem Assembly (included in item 4)* |
| 5 | 11-01157-08-550 | Ring Locknut |
| 6 | 11-00742-43-890 | Screw |
| 7 | 60-26854-51-550 | Projector Supply Line |
| 8 | 60-06429-51-590 | Push Button Stem Assembly* |
| 9 | 40-26741-43-730 | Lever Arm |
| 10 | 10-26399-08-640 | Drain Plug |
| 11 | 16-02705-08-640 | Strainer Plate |
| 12 | 10-01471-40-560 | Waste Gasket |
| 13 | 60-06884-51-550 | Waste Line Assembly |
| 14 | 10-06876-08-640 | Glass Filler Button (not shown) |
| 15 | 17-06740-42-830 | Receptor |
| 16 | 11-06694-43-890 | Receptor Screws (2 each) |
| 17 | 60-07748-51-550 | Lowside Assembly |
| 18 | 60-07938-51-550 | Primary Temperature Control |
| 19 | 60-07932-51-550 | Secondary Temperature Control |
| 20 | 19-42334-51-550 | Compressor |
| 21 | 19-42351-51-550 | Relay |
| 22 | 19-42336-51-550 | Overload |
| 23 | 60-26558-51-960 | Condenser |
| 24 | 60-26556-51-550 | Condenser Water Valve |
| 25 | 60-10108-51-550 | Capillary Heat Exchanger |
| 26 | 19-14042-04-550 | Junction Box |
| 27 | 40-06973-43-XXX | Front Panel (not shown) |

* Look for detailed schematic of this part in Detailed Parts Section

XXX - See Page I-A for Color Chart

MODEL XP16W-1

| MODEL# | MFG DATE S/N ENDING | COLD WATER CAP* | COMP HP | VOLTAGE ± 10 | PH | HZ | TOTAL AMPS | R-12 REFRIG CHARGE* | WATER INLET PSIG |
|---------|---------------------------|-----------------------|------------|-----------------|----|----|---------------|---------------------------|------------------------|
| XP16W-1 | D91 - Current | 16GPH | 1/5 | 110 | 1 | 60 | 5.0 | 8 oz. | 20-90 |
| | | | | | | | | | |

HEIGHT: 43 3/4"

WIDTH: 16"

DEPTH: 13 1/4"

*ARI ratings: capacity at GPH cooled to 50° with 90°F ambient temperature and 80°F inlet water.

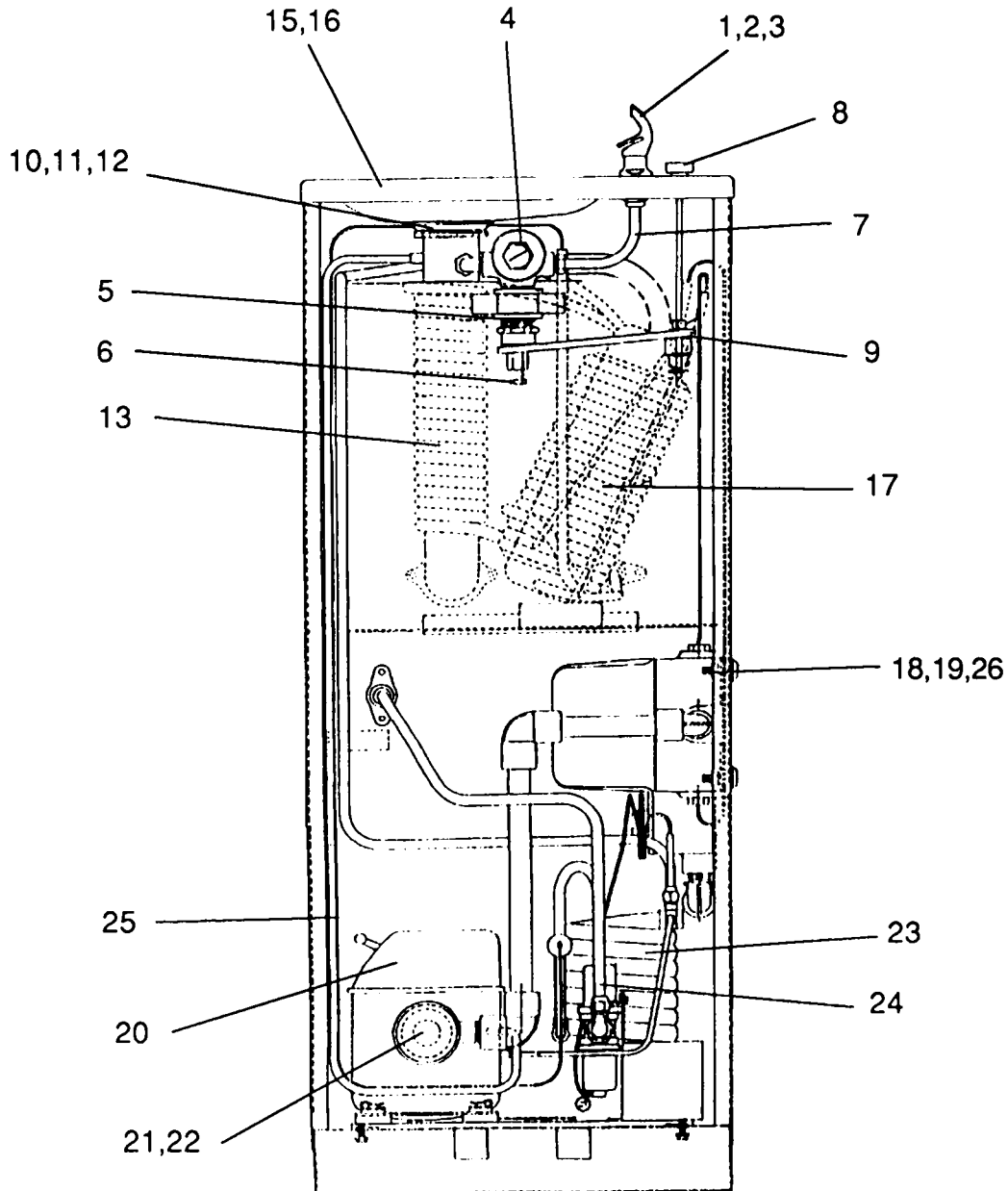

To order parts, contact your nearest Halsey Taylor wholesaler or representative.

Continued product improvement makes specifications subject to change without notice.

Halsey Taylor.