

**INSTALLATION INSTRUCTIONS:**

- A- REFERENCE DRAWING # 9938-340-001 FOR INSTALLATION OF -FRU1 UNDERGROUND FREEZE RESISTANT VALVE ASSEMBLY.
- B- PROVIDE 30" SQUARE MINIMUM x 6" DEEP MINIMUM CONCRETE SLAB BY OTHERS TO SECURELY ANCHOR FIXTURE. INSTALL THE FOUR PROVIDED CONCRETE ANCHORS ① AT DIMENSIONS SHOWN TO MATCH HOLES ② IN FIXTURE BASE.
- C- PROVIDE FOR BUTTON AND WATER SUPPLY TUBING ENTRY INTO BOTTOM OF FIXTURE THRU 6" SQUARE OPENING.
- D- ROUGH-IN WASTE OUTLET ③ AT DIMENSION SHOWN FOR 1-1/4" OUTER DIAMETER PLAIN END TAILPIECE ④.
- E- CAREFULLY REMOVE FIXTURE ⑤ AND COMPONENTS FROM THE PACKAGING PREVENTING SCRATCHING AND DAMAGE.

- F- REMOVE BACK ACCESS PANEL ⑥. ENSURE PUSHBUTTON ⑦ WASTE TAILPIECE ④ AND BUBBLER ⑧ ARE SECURE AND CHECK ALL TUBING CONNECTIONS TO MAKE SURE THEY DID NOT COME LOOSE IN SHIPMENT.
- G- SET FIXTURE IN PLACE ALIGNING BASE HOLES ② WITH THE INSTALLED ANCHORS ① AND SECURE WITH THE 1/2" UNC HARDWARE ⑨ PROVIDED.
- H- MAKE-UP 1-1/4" O.D. WASTE CONNECTION TO TAILPIECE ④.
- I- RUN TUBING FROM FIXTURE TO FREEZE RESISTANT VALVE AND COMPLETE INSTALLATION FOLLOWING DWG # 9938-340-001.
- J- TEST OPERATION OF BUBBLER BY DEPRESSING BUTTON ⑦. CHECK ALL CONNECTIONS AND WASTE PIPING FOR LEAKS. CORRECT IF PRESENT.
- K- RE-INSTALL BACK ACCESS PANEL ⑥.

**ACORN AQUA**  
P.O. Box 3527 City of Industry, CA 91744  
Phone: (800) 591-9360 www.acornaqua.com

TITLE <b>-FRU1 FREEZE RESISTANT SQUARE OUTDOOR STEEL DRINKING FOUNTAIN</b>		
MANUFACTURE DATE <b>JANUARY 2006 TO PRESENT</b>	DATE ISSUED <b>09/27/05</b>	DRAWING NUMBER <b>9938-157-001</b>
	DATE REVISED	

**NOTES:**

- 1- FOLLOW ALL LOCAL, STATE AND FEDERAL CODES WHEN INSTALLING.
- 2- LOCAL GROUND CONDITIONS MAY REQUIRE GREATER THAN MINIMUM 5 CUBIC FEET OF POROUS GRAVEL FILL.
- 3- INSULATED VALVE BOX IS REQUIRED. AVAILABLE AS OPTION -GVB GROUND VALVE BOX FROM ACORN AQUA.
- 4- PVC BURY VALVE CASING TO BE FIELD CUT FOR APPROPRIATE DEPTH BELOW THE FROST LINE.
- 5- INSTALL AN INLET FILTER IF WATER SUPPLY HAS A SEDIMENT OR MINERAL CONTENT PROBLEM.

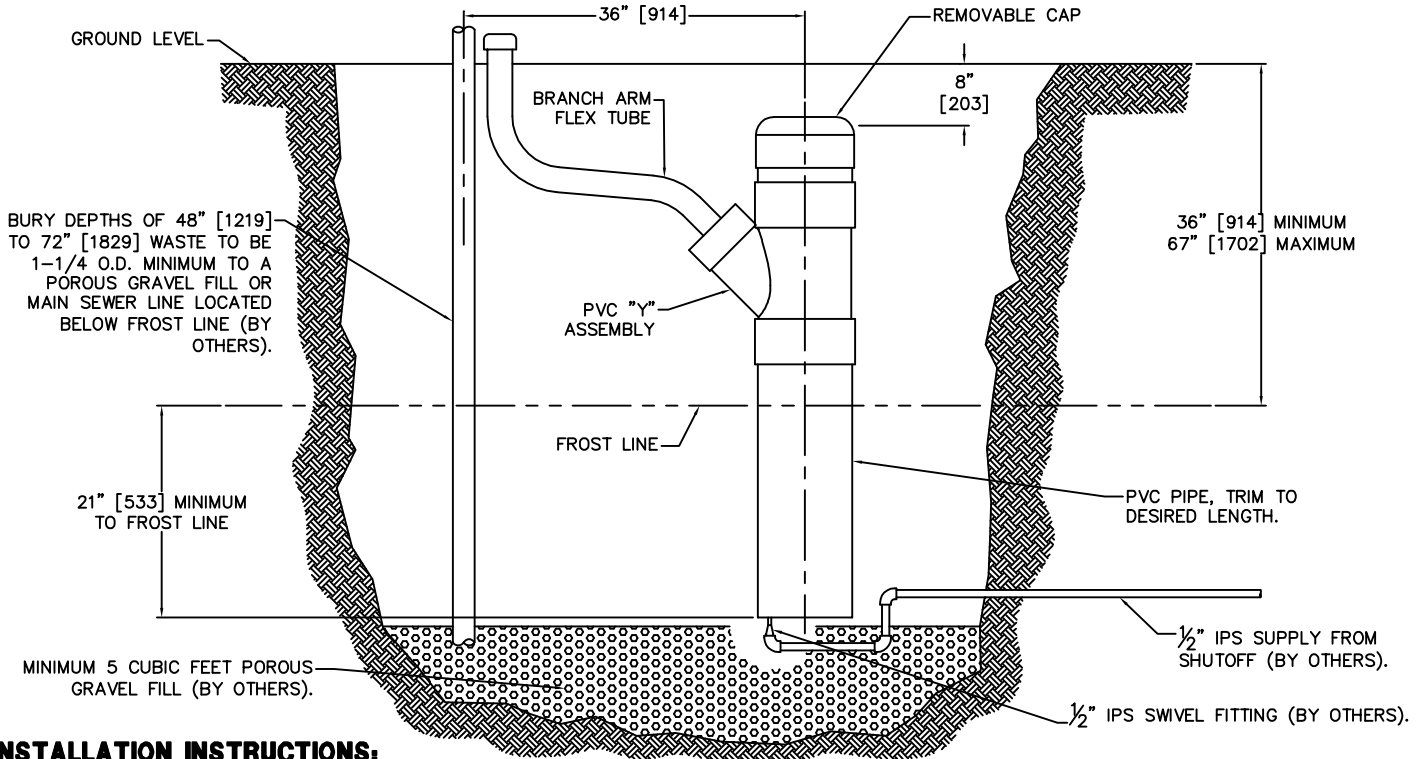

**INSTALLATION INSTRUCTIONS:**

- A- DIG PIT WIDE ENOUGH TO ALLOW SPACING OF 36" FROM CENTERLINE OF PVC PIPE CASING TO CENTERLINE OF DRINKING FOUNTAIN WASTE PIPING BY OTHERS. DETERMINE FROST LINE DEPTH. DIG PIT DEEP ENOUGH TO HAVE A MINIMUM OF 5 CUBIC FEET OF POROUS GRAVEL FILL WITH THE TOP OF IT AT NO MORE THAN 21" BELOW THE FROST LINE.
- B- RUN SUPPLY LINE BY OTHERS AND WASTE LINE (IF NOT DRAINING INTO GROUND) BY OTHERS TO PIT BELOW FROST LINE. PROVIDE SUPPLY MAINTENANCE SHUT OFF VALVE BY OTHERS. PROVIDE 1/2" IPS SWIVEL FITTING BY OTHERS ON END OF SUPPLY BELOW WHERE PVC PIPE CASING WILL END 21" MINIMUM BELOW FROST LINE. PLACE WASTE PIPING BY OTHERS WITH END PROTRUDING ABOVE GROUND LEVEL WITHIN MOUNTING BOLT PATTERN AT DRINKING FOUNTAIN LOCATION AND OTHER END EITHER TO DRAIN INTO GROUND OR CONNECT TO WASTE LINE.
- C- BACK FILL WITH POROUS GRAVEL. MAKE SURE THAT TOP SURFACE OF GRAVEL IS AT LEAST 21" BELOW FROST LINE. LEAVE TEMPORARY ACCESS THROUGH GRAVEL TO SUPPLY CONNECTION. ATTACH LOOSE SUPPLY HOSE TO 1/2" IPS SWIVEL FITTING BY OTHERS.
- D- FIELD CUT PVC CASING PIPE AT END TO BE BURIED SO THAT IT WILL BE 21" MINIMUM BELOW THE FROST LINE. PLACE PVC CASING PIPE. ATTACH "Y" FITTING TO PIPE WITH PVC PRIMER AND GLUE BY OTHERS WITH BRANCH TOWARDS FOUNTAIN LOCATION. PULL SUPPLY HOSE UP THROUGH THE CASING. TRIM SUPPLY HOSE TO LENGTH TO ALLOW VALVE MAINTENANCE ABOVE GROUND LEVEL.
- E- FLUSH WATER SUPPLY OF ALL DEBRIS BEFORE ATTACHING VALVE. ASSEMBLE SUPPLY HOSE TO VALVE AT GROUND LEVEL AND PRESSURE TEST FOR LEAKS. ONCE IT IS CONFIRMED THERE IS NO LEAKING, COMPLETE GRAVEL FILL AROUND SUPPLY CONNECTION LEFT ACCESSIBLE IN STEP C. LOWER VALVE ASSEMBLY INTO CASING USING ATTACHED ROD. FIELD CUT ROD TO LENGTH. COIL SUPPLY HOSE UNDERNEATH VALVE WITHOUT KINKING.
- F- ASSEMBLE BRANCH ARM FLEX TUBE FOR PUSH BUTTON AND BUBBLER TUBING TO PVC "Y" BRANCH CASING BEING SURE TO PLACE OTHER END WITHIN MOUNTING BOLT PATTERN AT DRINKING FOUNTAIN LOCATION. CAP CASING AND BACK FILL SITE MAKING SURE EVERYTHING REMAINS IN PROPER POSITION.

**INSTALLATION CONTINUES FOR -FRU1 ON DRAWING \* 9938-341-001, -FRU2 ON DRAWING \* 9938-342-001, -FRU3 ON DRAWING \* 9938-343-001, AND -FRU4 ON DRAWING \* 9938-344-001.**

 <b>ACORN AQUA</b> P.O. Box 3527 City of Industry, CA 91744 Phone: (800) 591-9360 www.acornaqua.com	<b>TITLE</b> <b>OPTIONAL -FRU UNDERGROUND FREEZE RESISTANT VALVE SYSTEM</b>		
	<b>MANUFACTURE DATE</b> <b>JANUARY 2006</b> <b>TO PRESENT</b>	<b>DATE ISSUED</b> <b>11/11/05</b> <b>DATE REVISED</b> <b>04/17/07</b>	<b>DRAWING NUMBER</b> <b>9938-340-001</b>

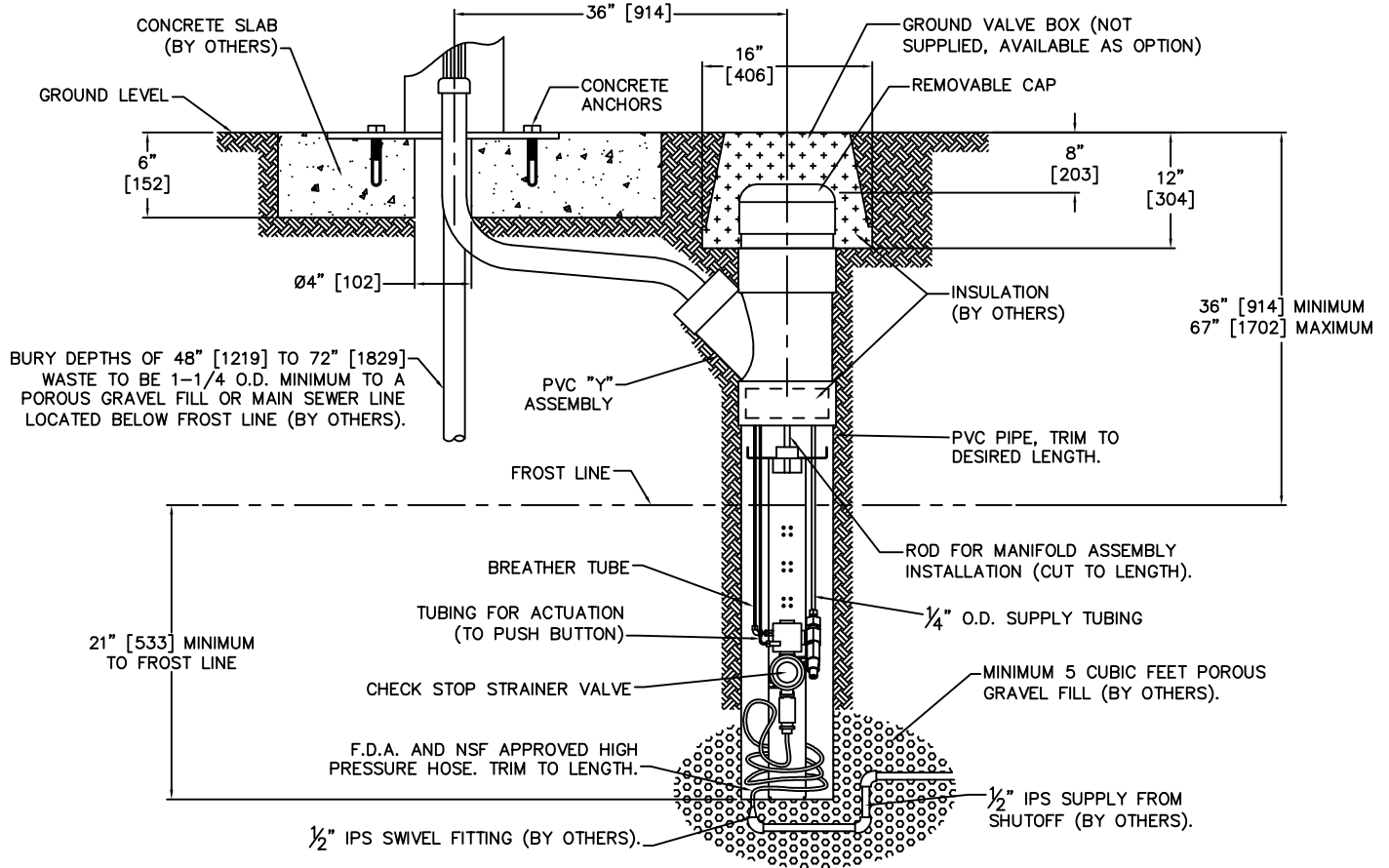

**INSTALLATION INSTRUCTIONS CONTINUE ON THIS DRAWING FROM INITIAL STEPS ON DRAWING # 9938-340-001.**

**INSTALLATION INSTRUCTIONS:**

- G- AFTER BACK FILLING SITE AROUND WASTE PIPING BY OTHERS AND PVC PIPE CASING, INSTALL GROUND VALVE BOX (BY OTHERS OR AVAILABLE AS OPTION -GVB FROM ACORN AQUA) ABOVE THE PVC PIPE CASING AND POUR CONCRETE PAD FOR DRINKING FOUNTAIN. CONCRETE PAD MUST HAVE 4" DIAMETER OPENING FOR THE WASTE PIPING AND BRANCH ARM FLEX TUBE FROM CASING AT PROPER LOCATION WITHIN THE FOUNTAIN MOUNTING BOLT PATTERN WITH THE CENTER OF THE UNIT BEING 36" AWAY FROM THE CENTERLINE OF THE CASING.
- H- ALLOW THE CONCRETE PAD TO CURE PROPERLY. INSTALL CONCRETE ANCHORS AND COMPLETE THE INSTALLATION OF DRINKING FOUNTAIN REFERENCING THE APPROPRIATE FIXTURE INSTALLATION INSTRUCTIONS.
- I- CONNECT 1/8" O.D. ACTUATION TUBING TO PUSHBUTTON AND 1/4" O.D SUPPLY TUBING TO BUBBLER. TAPE BREATHER TUBE END TO ACTUATION TUBING WITHIN FIXTURE LEAVING THE END OPEN TO THE ATMOSPHERE. REMOVE PVC PIPE CASING CAP AND RAISE VALVE ASSEMBLY TO GROUND LEVEL OUTSIDE CASING. RUN ACTUATION, BREATHER AND SUPPLY TUBING FROM WITHIN FIXTURE DOWN THROUGH THE BRANCH ARM FLEX TUBE INTO THE PVC PIPE CASING. RETRIEVE TUBING ENDS FROM WITHIN CASING. TEMPORARILY CONNECT TUBING TO VALVE AND LOWER INTO CASING. OBSERVE WHERE THERE MIGHT BE EXCESS TUBING. RAISE VALVE AGAIN AND TRIM TUBING TO LENGTH TO ALLOW FOR GROUND LEVEL MAINTENANCE AND PLACEMENT OF VALVE ASSEMBLY AT BOTTOM OF CASING. RE-CONNECT TUBING ONCE TRIMMED.
- J- BEFORE LOWERING VALVE INTO CASING, TURN ON WATER SUPPLY AND TEST FOR PROPER OPERATION DEPRESSING PUSH BUTTON. CHECK FOR LEAKS. LOWER VALVE ASSEMBLY INTO CASING COILING SUPPLY HOSE UNDERNEATH IT WITHOUT KINKING. RE-TEST FOR PROPER OPERATION AND VERIFY NO LEAKING. SUPPLY TUBING FROM VALVE TO BUBBLER MUST HAVE A STRAIGHT RUN WITH NO LOW SPOTS WHERE WATER MAY COLLECT AND FREEZE. ENSURE WATER DRAINS OUT OF SUPPLY LINE AT VALVE ASSEMBLY INTO GRAVEL FILL WHEN FLOW STOPS.
- K- INSTALL DRINKING FOUNTAIN ACCESS PANELS. PLACE INSULATION BY OTHERS IN VALVE CASING AS SHOWN AND CAP. PLACE INSULATION BY OTHERS OVER CAP WITHIN GROUND VALVE BOX (BY OTHERS OR AVAILABLE OPTION) AND COVER.

<p><b>ACORN AQUA</b> P.O. Box 3527 City of Industry, CA 91744 Phone: (800) 591-9360 www.acornaqua.com</p>	<p>TITLE <b>OPTIONAL -FRU1 UNDERGROUND FREEZE RESISTANT VALVE SYSTEM</b></p>		
	<p>MANUFACTURE DATE</p> <p><b>JANUARY 2006</b></p> <p><b>TO PRESENT</b></p>	<p>DATE ISSUED</p> <p><b>11/11/05</b></p>	<p>DRAWING NUMBER</p> <p><b>9938-341-001</b></p>
		<p>DATE REVISED</p> <p><b>04/17/07</b></p>	

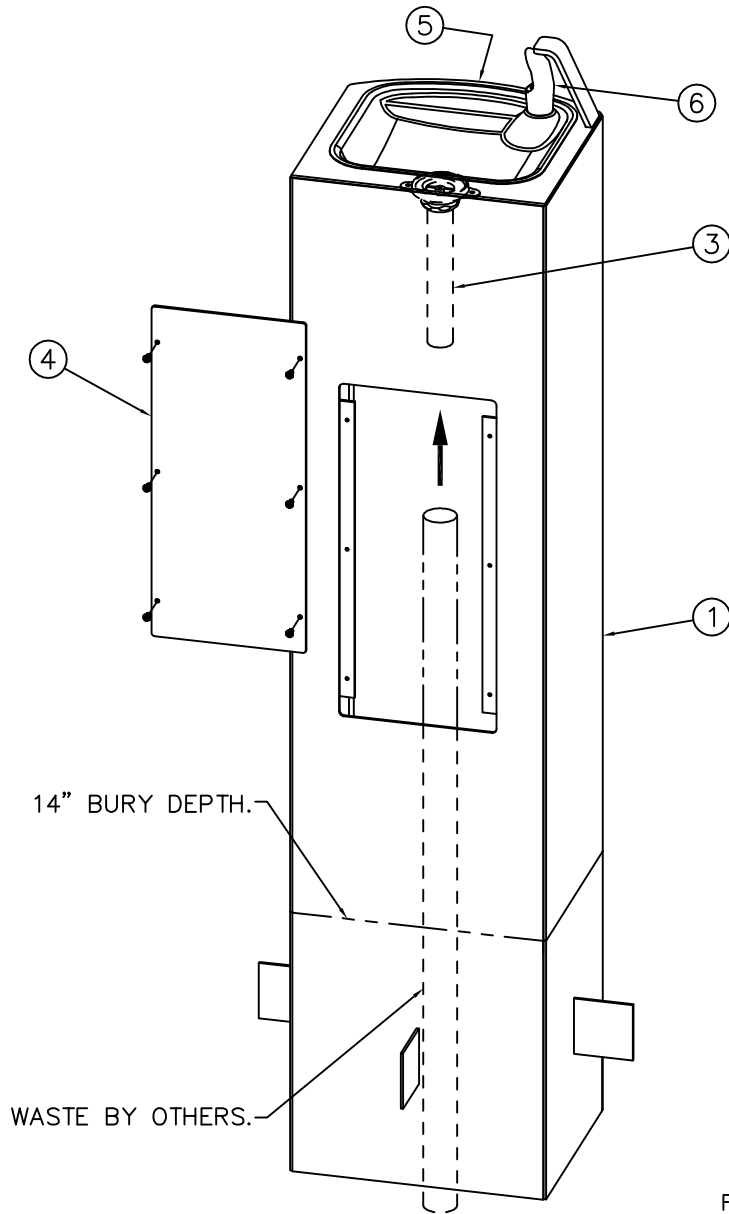

**BASE ROUGH-IN VIEW**

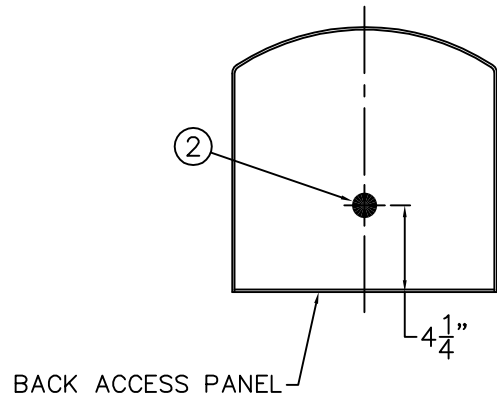

**INSTALLATION INSTRUCTIONS:**

- A- REFERENCE DRAWING # 9938-340-001 FOR INSTALLATION OF -FRU1 UNDERGROUND FREEZE RESISTANT VALVE ASSEMBLY.
- B- PREPARE INSTALLATION LOCATION TO BURY FIXTURE PEDESTAL (1) TO 14" DEPTH.
- C- PROVIDE FOR BUTTON AND WATER SUPPLY TUBING ENTRY INTO BOTTOM OF FIXTURE.
- D- ROUGH-IN WASTE OUTLET (2) AT DIMENSION SHOWN FOR 1-1/4" OUTER DIAMETER PLAIN END TAILPIECE (3).
- E- CAREFULLY REMOVE THE FIXTURE AND COMPONENTS FROM THE PACKAGING PREVENTING SCRATCHING AND DAMAGE.

- F- SET FIXTURE IN PLACE TO 14" BURY DEPTH. ENSURE IT IS VERTICAL ALL AROUND. POUR CONCRETE. ALLOW TO CURE.
- G- REMOVE BACK ACCESS PANEL (4). ENSURE PUSHBUTTON (5) WASTE TAILPIECE (3), AND BUBBLER (6) ARE SECURE AND CHECK ALL THE TUBING CONNECTIONS TO MAKE SURE THEY DID NOT COME LOOSE IN SHIPMENT.
- H- MAKE-UP 1-1/4" O.D. WASTE CONNECTION TO TAILPIECE (3).
- I- RUN TUBING FROM FIXTURE TO FREEZE RESISTANT VALVE AND COMPLETE INSTALLATION FOLLOWING DWG # 9938-340-001.
- J- TEST OPERATION OF BUBBLER BY DEPRESSING BUTTON (5). CHECK ALL CONNECTIONS AND WASTE PIPING FOR LEAKS. CORRECT IF PRESENT.
- K- RE-INSTALL BACK ACCESS PANEL (4).

**ACORN AQUA**  
P.O. Box 3527 City of Industry, CA 91744  
Phone: (800) 591-9360 www.acornaqua.com

TITLE <b>-FRU1 FREEZE RESISTANT -IGM IN-GROUND MOUNTING SQUARE FOUNTAIN</b>		
MANUFACTURE DATE <b>JANUARY 2006 TO PRESENT</b>	DATE ISSUED <b>09/27/05</b>	DRAWING NUMBER <b>9938-158-001</b>
	DATE REVISED	

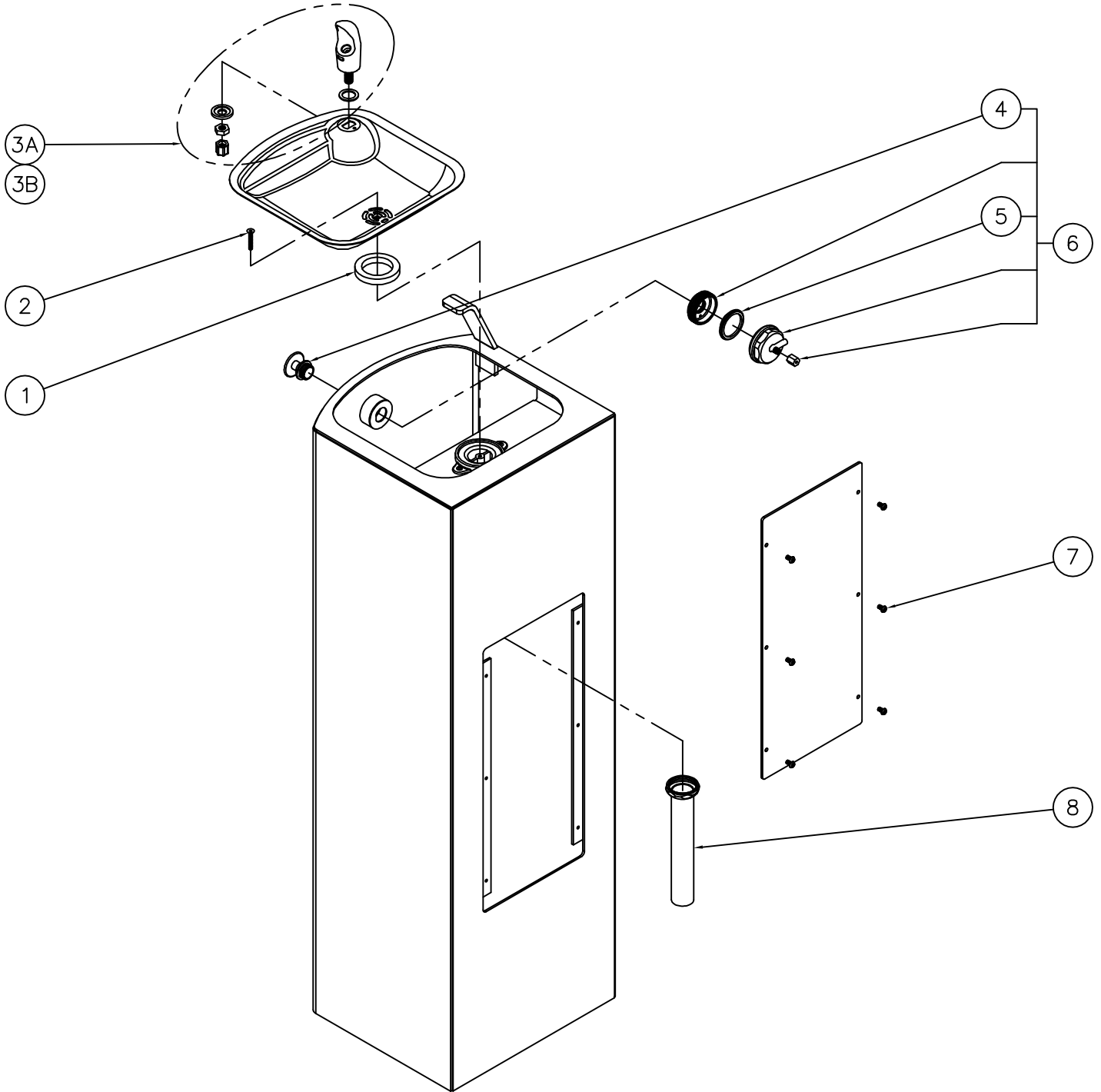

1	7000-006-000	FLAT DRAIN ADAPTER GASKET	5	2566-001-000	DIAPHRAGM
2	0152-010-000	CENTER REJECT ALLEN FLAT HEAD SCREW	6	7004-608-001	PUSH BUTTON ASSEMBLY - OUTDOOR STEEL
3A	7000-002-001	STANDARD CHROME PLATED BRASS BUBBLER	7	0112-002-000	CENTER REJECT ALLEN BUTTON HEAD SCREW
3B	7000-410-002	"F" OPTION FLEXIBLE BUBBLER ASSEMBLY	8	7000-019-001	1-1/4" OUTER DIAMETER TAILPIECE
4	7004-608-002	PUSH BUTTON CAP ASSEMBLY			
ITEM	PART NUMBER	DESCRIPTION	ITEM	PART NUMBER	DESCRIPTION

<p><b>ACORN AQUA</b> P.O. Box 3527 City of Industry, CA 91744 Phone: (800) 591-9360 www.acornaqua.com</p>	<p>TITLE <b>-FRU1 FREEZE RESISTANT SQUARE OUTDOOR STEEL DRINKING FOUNTAIN</b></p>		
	<p>MANUFACTURE DATE</p> <p><b>JANUARY 2006</b></p> <p><b>TO PRESENT</b></p>	<p>DATE ISSUED</p> <p><b>11/15/05</b></p>	<p>DRAWING NUMBER</p> <p><b>9938-157-500</b></p>
		<p>DATE REVISED</p> <p><b>03/03/06</b></p>	

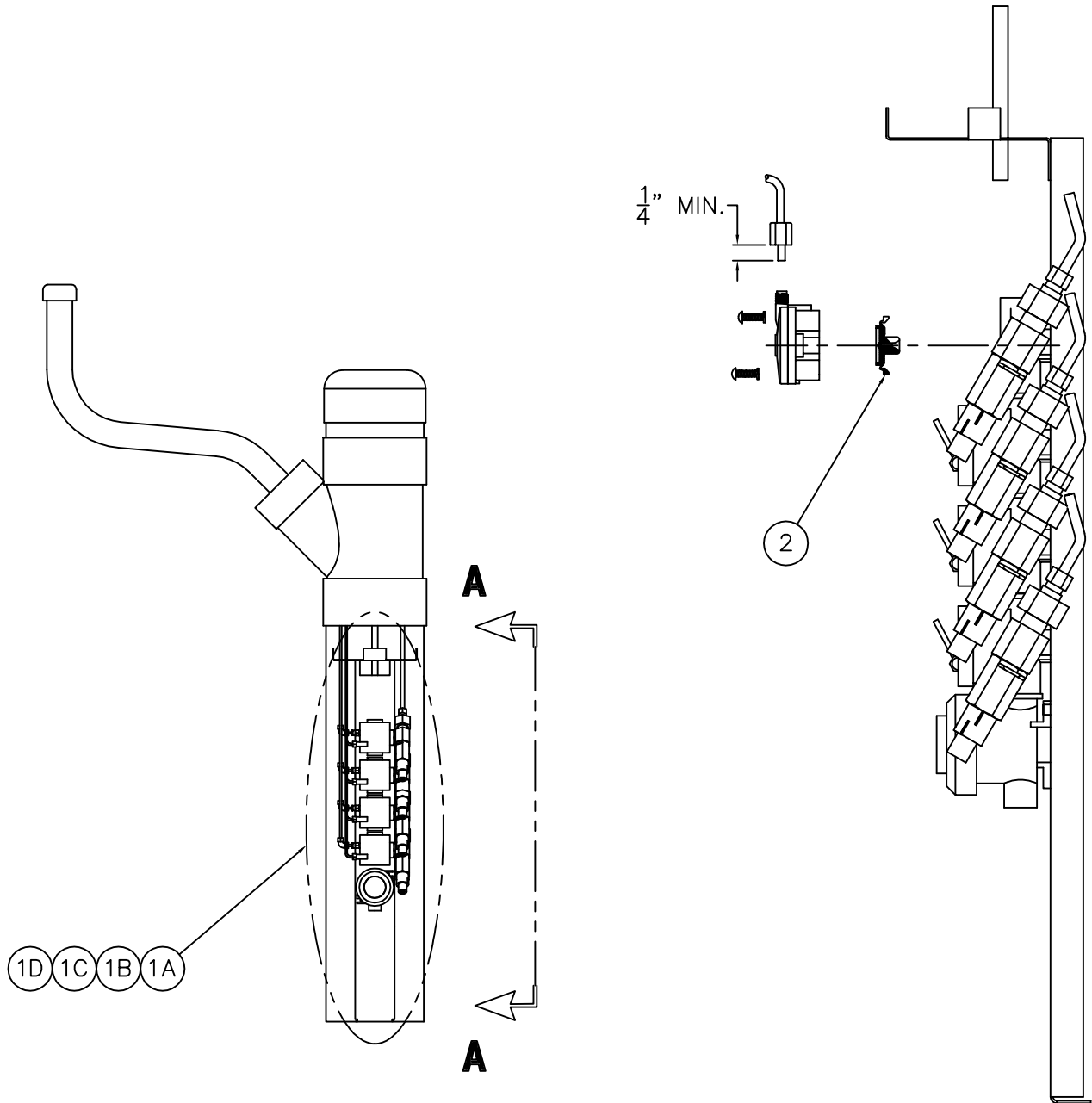



**VIEW A-A**

1A	7000-115-002	4-STATION FREEZE-RESISTANT VALVE ASSY.	1D	7000-132-002	1-STATION FREEZE-RESISTANT VALVE ASSY.
1B	7000-130-002	3-STATION FREEZE-RESISTANT VALVE ASSY.	2	2563-010-001	WATER DIAPHRAGM ASSEMBLY
1C	7000-131-002	2-STATION FREEZE-RESISTANT VALVE ASSY.			
ITEM	PART NUMBER	DESCRIPTION	ITEM	PART NUMBER	DESCRIPTION

<p><b>ACORN AQUA</b> P.O. Box 3527 City of Industry, CA 91744 Phone: (800) 591-9360 www.acornaqua.com</p>	<b>TITLE</b> <b>OPTIONAL -FRU FREEZE RESISTANT VALVE ASSEMBLIES</b>		
	<b>MANUFACTURE DATE</b> <b>JANUARY 2006</b> <b>TO PRESENT</b>	<b>DATE ISSUED</b> <b>11/11/05</b>	<b>DRAWING NUMBER</b> <b>9938-340-500</b>
		<b>DATE REVISED</b> <b>04/17/07</b>	

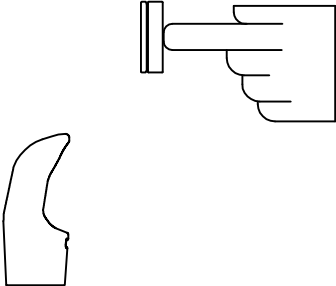

**PUSH PAD / PUSH BUTTON FREEZE RESISTANT & STONE DRINKING FOUNTAINS  
NON-METERING AIR-CONTROLLED VALVE - (DIRECT ACTING)**

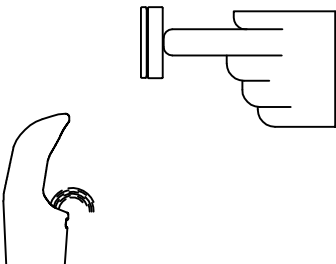
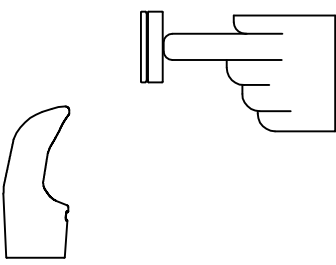
<b>CONDITION:</b>	<b>SOLUTION:</b>
<p><b>NO WATER FLOW:</b></p> 	<ol style="list-style-type: none"> <li>1.1 Check water main supply – open.</li> <li>1.2 Inspect checkstops – open.</li> <li>1.3 Inspect checkstop strainer for debris – clean.</li> <li>1.4 Check 1/8” O.D. tubing and fittings for leaks.</li> <li>1.5 Check pushbutton air diaphragm for holes.</li> <li>1.6 Check servomotor diaphragm center hole for blockage.</li> </ol>
<p><b>WATER DRIPS / WILL NOT SHUT OFF:</b></p> 	<ol style="list-style-type: none"> <li>2.1 Check servomotor diaphragm offset hole for debris.</li> <li>2.2 Check servomotor seat for build-up or damage.</li> <li>2.3 Check servomotor seat o-ring for damage.</li> <li>2.4 Check servomotor plate and diaphragm for obstruction.</li> </ol>
<p><b>REDUCED WATER FLOW:</b></p> 	<ol style="list-style-type: none"> <li>3.1 Check water main supply for 20 psig minimum flow pressure.</li> <li>3.2 Check valve riser tubing for crimping.</li> <li>3.3 Inspect checkstop strainer for debris – clean.</li> <li>3.4 Check valve flow control for blockage – clean.</li> <li>3.5 Inspect bubbler for debris – clean.</li> </ol>
<p><b>PREMATURE WATER SHUTOFF:</b></p> 	<ol style="list-style-type: none"> <li>4.1 Check 1/8” O.D. tubing and fittings for leaks.</li> <li>4.2 Check pushbutton air diaphragm for holes.</li> </ol>

Refer to Air-Controlled Valve Maintenance Detail on drawing # 9940-203-001 for -FRA\_ Above Ground units and on drawing # 9940-204-001 for Stone & -FRU\_ Below Ground units to locate solutions above.

<p><b>ACORN AQUA</b> P.O. Box 3527 City of Industry, CA 91744 Phone: (800) 591-9360 www.acornaqua.com</p>	<p>TITLE <b>STONE &amp; FREEZE RESISTANT FOUNTAIN VALVE MAINTENANCE INSTRUCTIONS</b></p>		
<p>MANUFACTURE DATE <b>JANUARY 2006</b> <b>TO PRESENT</b></p>	<p>DATE ISSUED <b>10/20/05</b></p>	<p>DRAWING NUMBER <b>9940-202-001</b></p>	
<p>DATE REVISED <b>11/20/06</b></p>			



**PUSH PAD / PUSH BUTTON STONE & BELOW GROUND FREEZE RESISTANT DRINKING FOUNTAINS  
NON-METERING AIR-CONTROLLED VALVE - (DIRECT ACTING)**

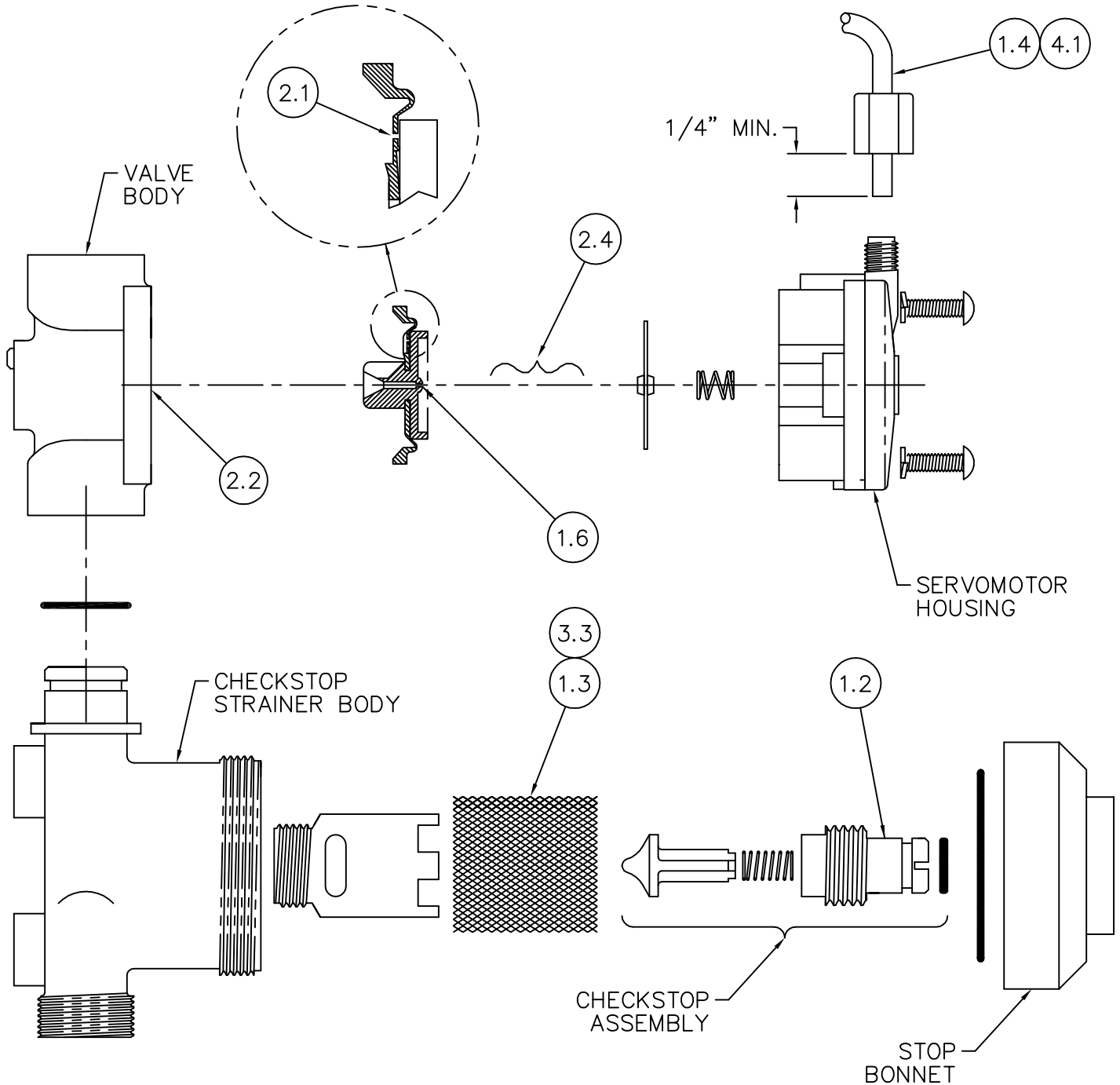

**CHECKSTOP STRAINER - SERVMOTOR DETAIL**

Refer to drawing #9940-202-001 for Valve Maintenance Instructions numbered solutions detailed above.

<p><b>ACORN AQUA</b> P.O. Box 3527 City of Industry, CA 91744 Phone: (800) 591-9360 www.acornaqua.com</p>	<p>TITLE <b>NON-METERING AIR-CONTROLLED VALVE MAINTENANCE INSTRUCTIONS</b></p>		
	<p>MANUFACTURE DATE <b>JANUARY 2006 TO PRESENT</b></p>	<p>DATE ISSUED <b>12/07/05</b></p>	<p>DRAWING NUMBER <b>9940-204-001</b></p>
		<p>DATE REVISED <b>11/20/06</b></p>	