

# Installation Instructions

## Thermostatic Mixing Valve (HL 200) with Optional Cabinet

**Model S59-3200 (Valve only)**

**Model S59-3200RE (with Recess-Mounted Enamel Cabinet)**

**Model S59-3200RS (with Recess-Mounted Stainless Steel Cabinet)**

**Model S59-3200SE (with Surface-Mounted Enamel Cabinet)**

**Model S59-3200SS (with Surface-Mounted Stainless Steel Cabinet)**

**Inlet Connections: 2" NPT**

**Outlet Connections: 2" NPT**

**Temperature Range: 90–120°F**

**Maximum Pressure: 125 PSIG**

**Inlet Temperature, Hot: 120°–200°F**

**Inlet Temperature, Cold: 33°–80°F**

**Minimum Temperature Differential (from valve set point): 20°F**



### IMPORTANT

**Installation and final temperature adjustment are the responsibility of the installer.**

**ASSE 1017, CSA & UPC Certified**



## Table of Contents

Pre-Installation Information	2
Installation Instructions	3
Recess-Mounted Cabinet Installation	4
Surface-Mounted Cabinet Installation	5
Recirculation Instructions	6
Maintenance	7-8
Troubleshooting	8-9
Parts Breakdown and Service Kits	10



## Pre-Installation Information

### Overview

The Model HL 200 Thermostatic Mixing Valve consists of a liquid-filled thermal motor and a piston control mechanism with positive shut-off of hot when there is a loss of cold water supply or thermostat failure. The valve body and cap is constructed of bronze with replaceable corrosion-resistant components, including a stainless steel piston and liner. The valve comes equipped with integral check stops that have removable strainers. The valve may be mounted in any position.

The valve controls temperature within  $\pm 3^\circ$  from a low flow to a maximum flow rate for a given pressure differential. The maximum inlet temperature of the valve is 200°F (93°C), and the maximum operating pressure is 125 PSI (860 kPA).

**Cabinet:** The optional recess-mounted or surface-mounted cabinet is constructed of 18-gauge stainless steel with a 16-gauge stainless steel door. The cabinet finish is either stainless steel or baked white enamel. The optional cabinet window is made of Plexiglass.

### Supplies recommended for installation:

- lockable shut-off on the outlet if tempered water is supplied to one or more remote showers
- lockable shut-off on the inlets/supplies
- (6) 3/8" wall anchors and fasteners for surface-mounted cabinet
- (4) 1/4" fasteners (and wall anchors, if necessary) for recess-mounted cabinet
- unions on all connections to facilitate removal of valve

### Tools required for temperature adjustment:

- 5/32" Allen key
- blade screwdriver

### Bradley Thermostatic Mixing Valve Warranty

Bradley Corporation warrants to commercial and institutional purchasers only each fixture free from defects in material and workmanship under normal use and service upon the following terms and conditions:

1. We will replace, without charge, any part which proves to be defective within one year from the date of our invoice at our option, F.O.B. Menomonee Falls, Wisconsin.
2. This warranty does not cover installation or any other labor charge and does not apply to fixtures which have been damaged by accident, abuse or improper maintenance.
3. The repair or replacement of the defective fixtures as stated in this warranty shall constitute the sole remedy of the purchaser, and the sole liability of the Bradley Corporation under this warranty. Bradley Corporation shall not otherwise be liable under any circumstances for incidental, consequential or indirect charges caused by defects in fixtures or any delay in the repair or replacement thereof.
4. This warranty extends only to commercial and institutional purchases and does not extend to any others, including consumer, customers of commercial and institutional purchasers.
5. This warranty is in lieu of all other warranties expressed or implied, including any implied warranty of merchant's ability or fitness for a particular purpose, or otherwise.

## Installation Instructions for Valve



**CAUTION:** If optional cabinet is to be used, the cabinet must be mounted before the valve is installed. Please refer to the cabinet mounting instructions on pages 4-5.

*NOTE:* Flush the supply lines before beginning installation.

*NOTE:* When the check valves are in the OPEN (operating) position, the cover screw for the stop/check stem will be flush with the valve cap (see Figure 1).

1. Connect the hot and cold valve supply inlets to the appropriate hot and cold supply piping.
2. Connect the mixed valve supply outlet from the valve to the tempered supply piping.
3. Screw the thermometer into the hole in the valve body (see Figure 2). The thermometer provides a readout of the outlet water temperature.
4. Pressurize the thermostatic mixing valve and check for pipe leaks.
5. Slowly open the outlet valve to fill the piping system.
6. Check the temperature when approximately 10 GPM water flow is reached (equivalent to four standard showers) and adjust if necessary (the range of the valve is 90°F–120°F (32°C–49°C). To adjust the temperature, follow the procedure below:
  - remove the slotted cover screw to expose the set screw
  - using a 5/32" hex-head Allen key, turn the set screw **counterclockwise** to **increase** the temperature or **clockwise** to **decrease** the temperature.
7. Shut the hot water inlet off by closing either the hot water check valve or inlet valve. While the hot water supply is turned off, check to make sure the cold water is reduced to less than 2 GPM. If the cold water is reduced properly, reopen the hot water supply.
8. Shut the cold water inlet off by closing either the cold water check valve or inlet valve. While the cold water supply is off, check to make sure that the hot water flow has shut down.

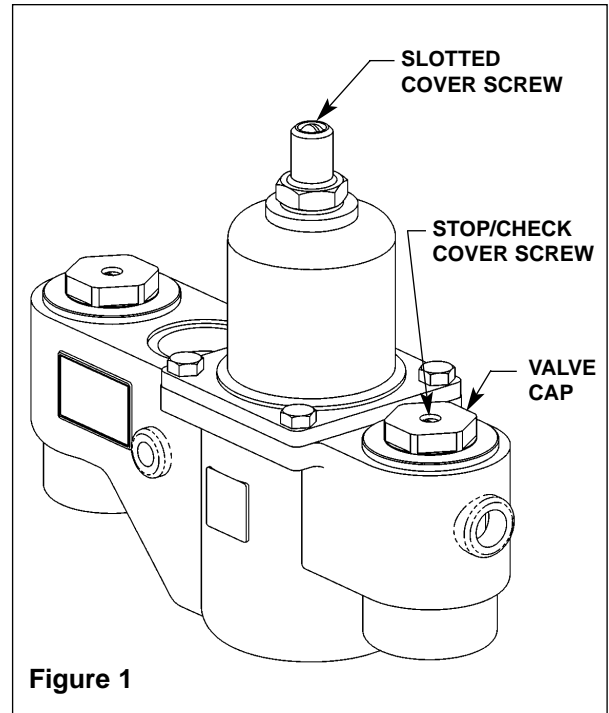

Figure 1

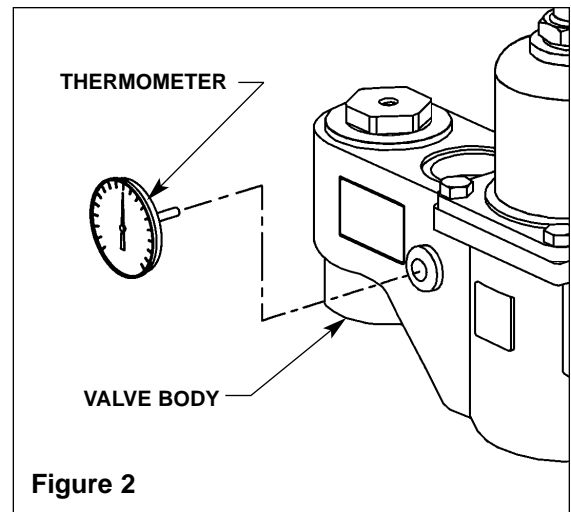

Figure 2

## Installation Instructions for Optional Recess-Mounted Cabinet

*NOTE: Flush the supply lines before beginning installation.*

1. Rough in a 28-1/2" W x 28-1/2" H hole in the wall for the cabinet (see Figure 3).
2. Measure and mark the cabinet mounting hole locations at the dimensions shown in Figure 3. Install four 1/4" wall anchors, if required (anchors supplied by installer).
3. Insert the cabinet into the wall opening and secure into place with four 1/4" wall fasteners (supplied by installer).
4. Install two anchors and screws through the valve bracket in back of the cabinet into a secure brace (supplied by installer) or into the wall. This must be done to provide adequate support for the valve.
5. Install the valve nipples and one-half of the union ball valve using pipe dope or teflon tape. Then install the other half of the union ball valve onto the inlet and outlet piping.
6. Insert the valve into the bracket in the cabinet (right side of the valve goes in first). Continue with the valve installation procedure found on page 3.
7. Position the wall flange tight to the wall and caulk in place.

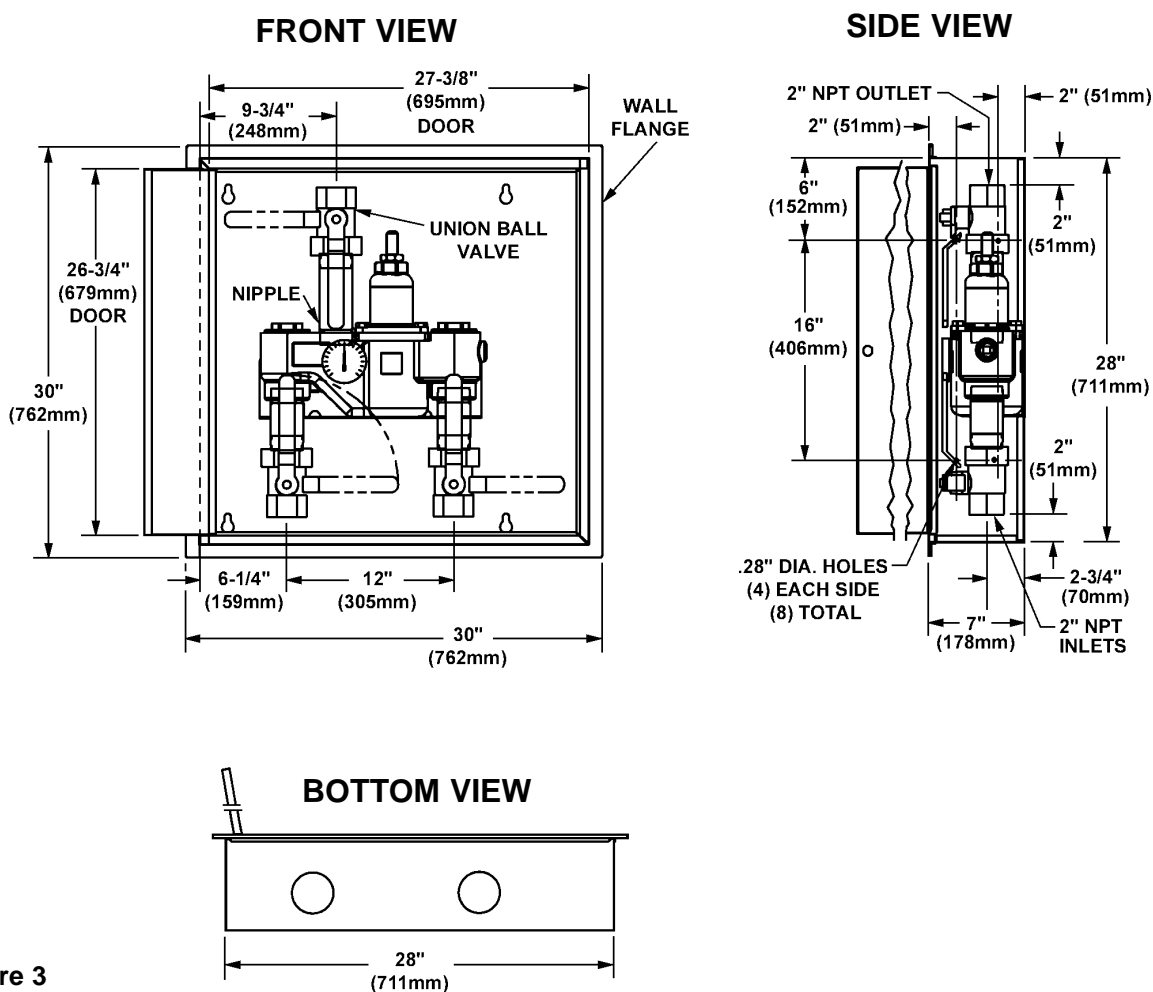

Figure 3

## Installation Instructions for Optional Surface-Mounted Cabinet

*NOTE: Flush the supply lines before beginning installation.*

1. Measure and mark the cabinet mounting hole locations at the dimensions shown in Figure 4. Install six 3/8" wall anchors (supplied by installer).
2. Position the cabinet onto the wall and secure into place with six 3/8" wall fasteners (supplied by installer).
3. Install the valve nipples and one-half of the union ball valve using pipe dope or teflon tape. Then install the other half of the union ball valve onto the inlet and outlet piping.
4. Insert the valve into the bracket in the cabinet (right side of the valve goes in first). Continue with the valve installation procedure found on page 3.

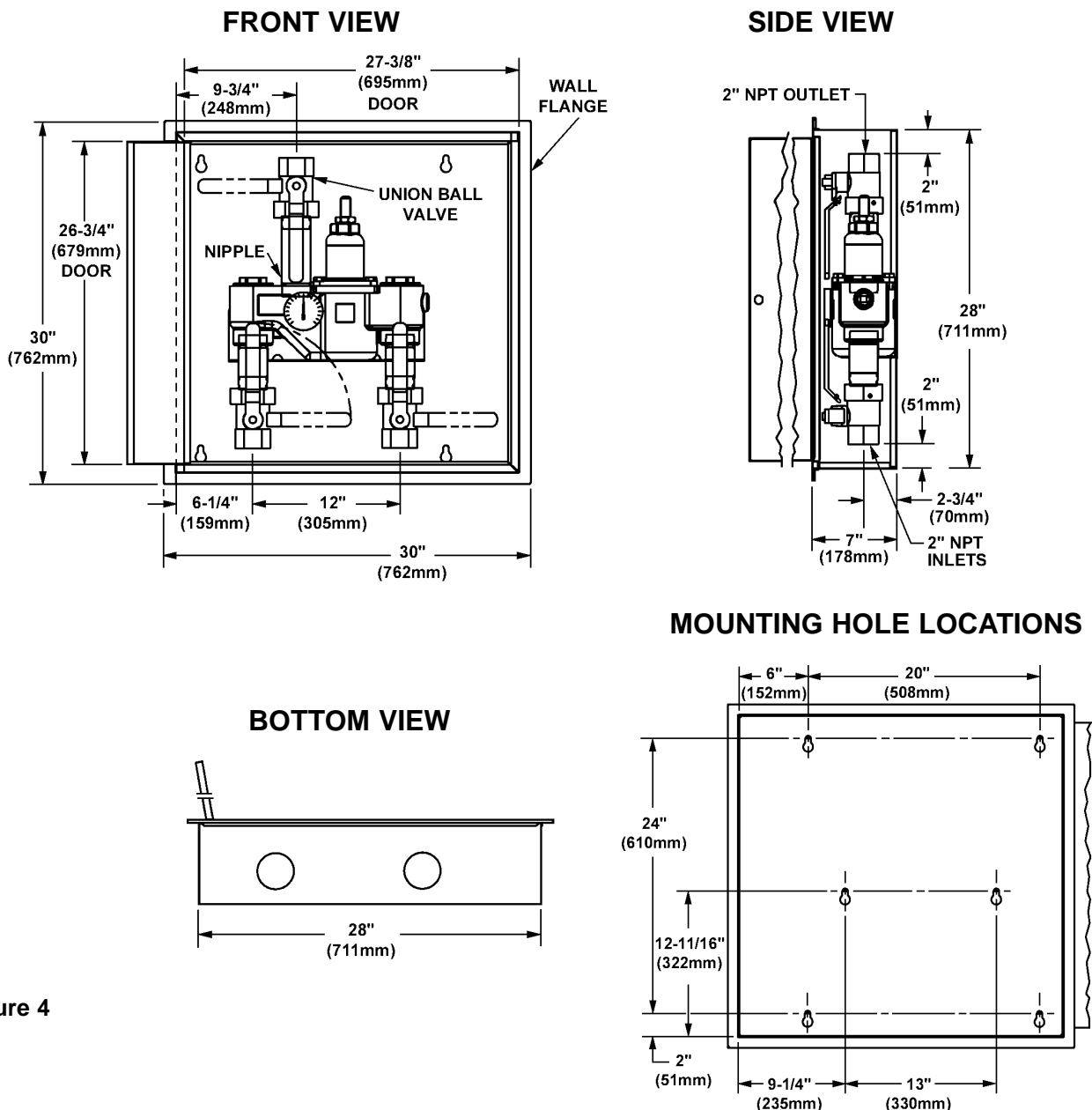
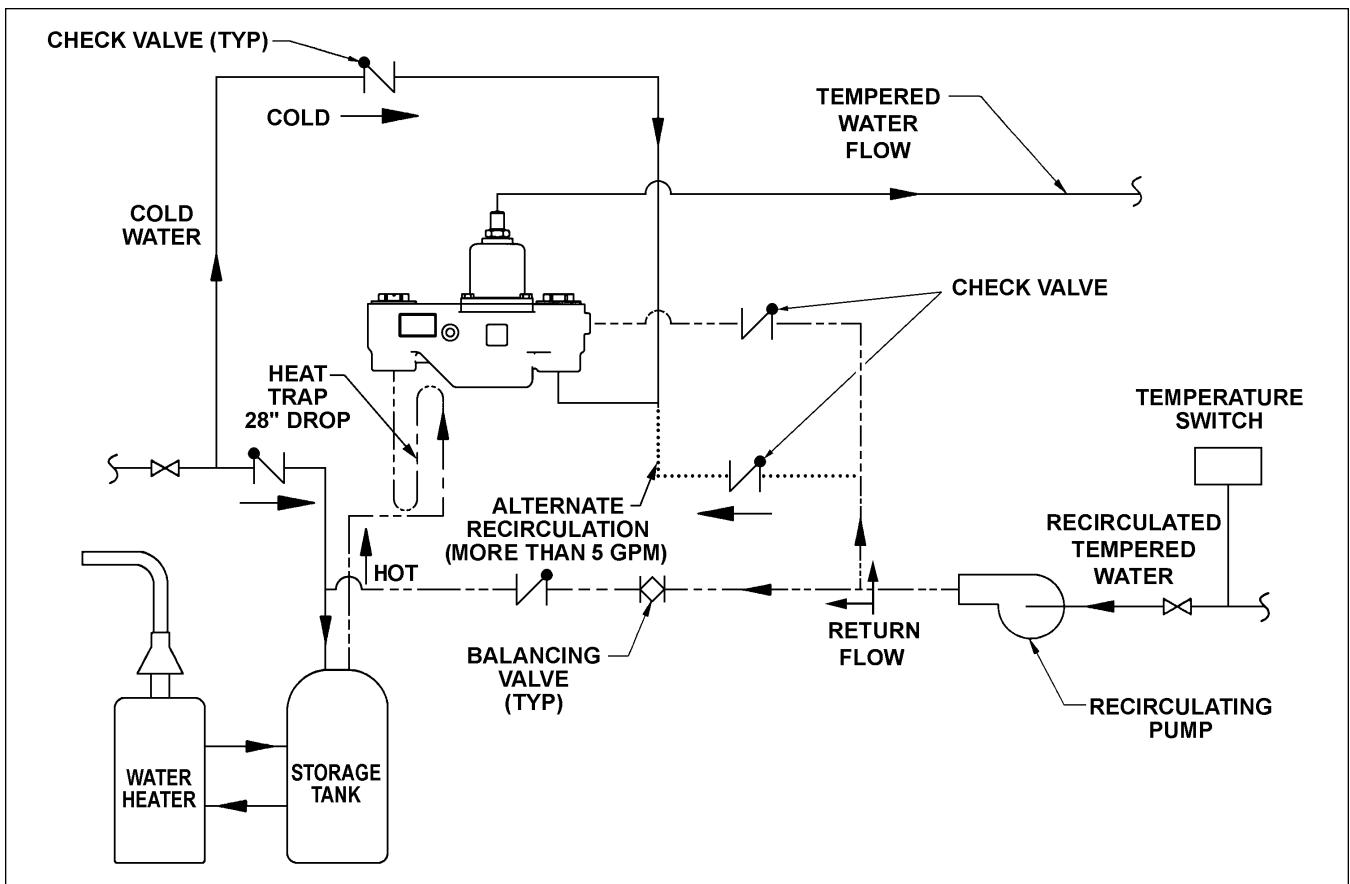

Figure 4

## Recirculation Diagram



## Recirculation Instructions

*NOTE: Recirculating the water in the system provides constant regulation of the water temperature. Flush the supply lines thoroughly after completing installation. Close off all fixtures and label them as not in use during the recirculating process.*

1. Turn off the recirculating pump and turn on the water supply (a water flow rate of 10-15 GPM is required).
2. Let the water run through the system until a consistent temperature is obtained. If you do not obtain the required temperature, refer to procedure #6 on page 3 for temperature readjustment.
3. As soon as the water reaches the proper temperature, turn on the recirculating pump (make certain the proper system temperature has been achieved before proceeding).
4. Check the water temperature at the return pump. If the temperature exceeds the appropriate level by 2°F, adjust the temperature high-limit switch (this will turn off the pump). Wait until the return water temperature is 5°F below the appropriate level and adjust the low limit switch (this will turn the pump back on).
5. Turn the balancing valve until it is completely open.
6. Turn off all fixtures and make sure there is no water running through the system (the cold inlet pipe should feel warm to the touch).
7. Let the system run for thirty minutes or longer without water. If, after thirty minutes, the water temperature increases, you may readjust the temperature by slowly closing the balancing valve until the appropriate temperature is reached.

## Thermostatic Mixing Valve Maintenance

For maximum efficiency, your thermostatic mixing valve requires a minimum amount of maintenance. Follow the procedures outlined below to achieve highest performance.



**WARNING:** To prevent injuries, use proper protective equipment for eyes and skin when using a propane torch.

### Check the piston for smooth movement

To check the valve's piston for free and smooth movement, follow the procedures outlined below:

1. Remove the valve's top cap and pull out the push rod and then the thermostat (see Figure 5). You may use a needlenose pliers to remove the thermostat from the valve body if desired.
2. Insert a 7/16" dia. rod into the valve and into the piston overhear chamber. Mark the length of the rod inside the valve (see Figure 6).

3. Push the rod until the piston stops and mark the new length of the dowel (the new length should be approximately 9/16" longer than the original length) (see Figure 6). If the length of the dowel is not as it should be, the piston is not moving freely and needs to be cleaned along with the piston liner. Clean the piston and liner following the method outlined below:

- remove the control section assembly from the valve body
- remove the top cap and thermostat
- unthread the liner from the cap (it is glued together; the O-rings must be removed and a propane torch may be required to melt the glue and loosen the liner)
- any cleaner suitable for brass and stainless steel may be used (if cleaning with suitable cleaner is not sufficient to remove debris, a 400-grit sandpaper may be used to polish and hone the piston and liner).

4. If the piston moves freely, push the mechanism up and down several times to make sure the piston moves smoothly and consistently. If movement of the piston is not consistent, recheck the piston and liner for dirt and debris as described in procedure #3.
  - if the piston parts need to be replaced, contact your Bradley representative and ask for Piston/Liner Kit (part number S65-196).

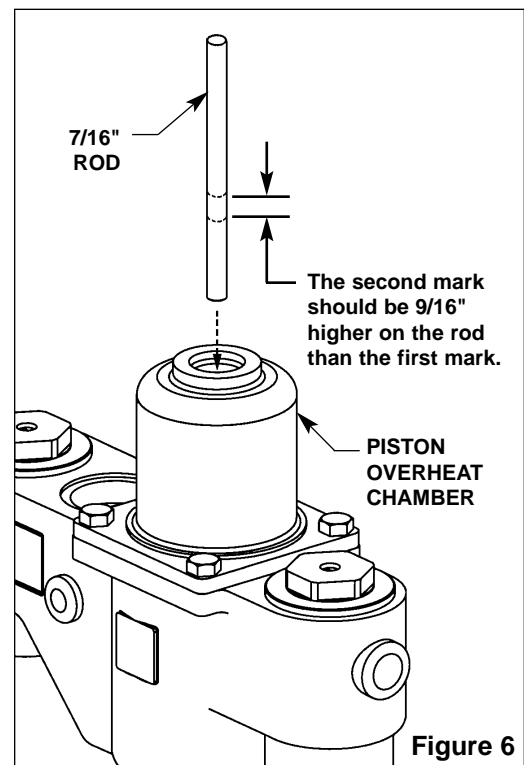
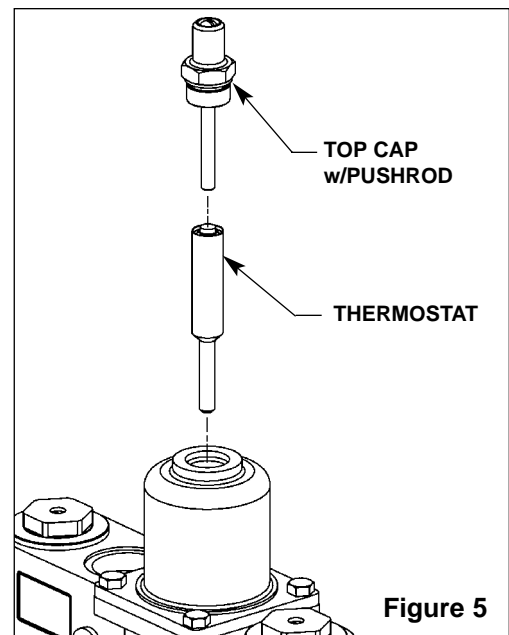

## Thermostatic Mixing Valve Maintenance *continued . . .*

### Check the thermostat for proper operation

To check the valve's thermostat for proper operation, follow the procedures outlined below.

1. Remove the top cap and pull out the push rod and thermostat (see Figure 5 on page 7).
2. Insert a 7/16" dia. rod into the thermostat bellows. Mark the length of the rod inside the bellows (see Figure 7).
3. Use a marking pen to mark the thermostat bellows length (at room temperature, with 10 lb. of force, the bellows length should be approximately 2.6") (see Figure 7).
4. If the thermostat bellows length is not in the proper range, the thermostat must be replaced (it cannot be repaired). Contact your Bradley representative and ask for Thermostat Kit (part number S65-194).

### Adjust the temperature

To adjust the valve's temperature to other than the factory preset, follow the procedures outlined below.

1. Turn on the water and let it run until at least 10 GPM is flowing through the valve.
2. Remove the slotted cover screw to expose the set screw.
3. Using a 5/32" hex-head Allen key, turn the set screw **counterclockwise** to **increase** the temperature or **clockwise** to **decrease** the temperature.
4. When the adjustment is complete, replace the cover screw and turn off the water.

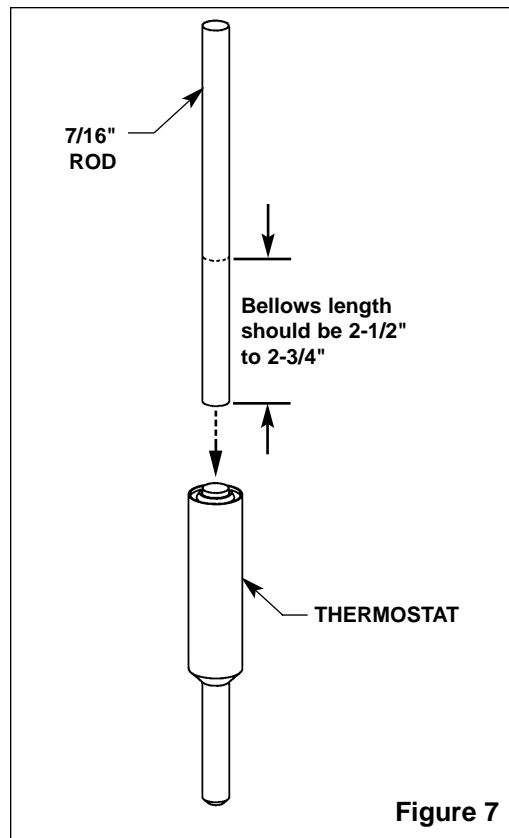

Figure 7

## Thermostatic Mixing Valve Troubleshooting

*NOTE: Before attempting to troubleshoot the valve or disassemble the components, check for the following conditions:*

- make sure that the check valves are fully open (the slotted stem must be flush with the stop/check cap) (see Figure 1 on page 3) and that all inlet and outlet shut-off valves are open
- make sure that the hot and cold inlet pipes are connected properly, and that there are no cross-connections or leaking stop/check valves
- check the hot water heater output to make sure that it is at least 15° F above the set temperature.

*Be sure to close the appropriate shut-off valves prior to disassembly of the valve and reopen the valves after inspection and repair is complete.*

### Problem: No water flow

*Cause: The thermostat has failed and subsequently, the safety shut-off has engaged.*

*Solution: See "Check the thermostat for proper operation" above and follow the step-by-step procedure.*



## Thermostatic Mixing Valve Troubleshooting *continued* . . .

### **Problem: Limited water flow**

*Cause: The stop and check sections of the valve do not move freely.*

**Solution:** Dirt and debris have collected on the check screen or seat, limiting the movement of the stop and checks. Remove the stop and checks, clean the screen and seat and reassemble the valve (see Figure 8). Do not remove the seat. The components may be scraped with a screwdriver to remove debris. A pair of tweezers works well for pulling debris out from the seat. If the stop and checks need to be replaced, contact your Bradley representative and ask for Check/Stop Kit (part number S65-190).

### **Problem: Improper water temperature**

*Cause: Valve temperature is not properly set.*

**Solution:** See "Adjust the temperature" on page 8 and follow the step-by-step procedure.

### **Problem: External leaks in the system**

*Cause: Either the NPT joints or O-rings have been damaged.*

**Solution:** Replace the O-rings where necessary. For replacement of O-rings, contact your Bradley representative and ask for O-Ring/Seal Kit (part number S65-195).

### **Problem: Temperature fluctuation**

*Cause: Thermostat is slowly failing.*

**Solution:** See "Check the thermostat for proper operation" on page 8 and follow the step-by-step procedure.

*Cause: Recirculation is not balanced.*

**Solution:** See "Recirculation instructions" on page 6 and follow the step-by-step procedure.

*Cause: Inlet supply line to the mixing valve is being shared by other pieces of equipment that are used only periodically, such as laundry appliances or washdown stations. It may reduce the inlet pressure to the mixing valve to less than 10 PSI. The supply line size may not be large enough to supply both the valve and the other appliances.*

**Solution:** Enlarge the supply line size, reconfigure the supply line or regulate the supply usage.

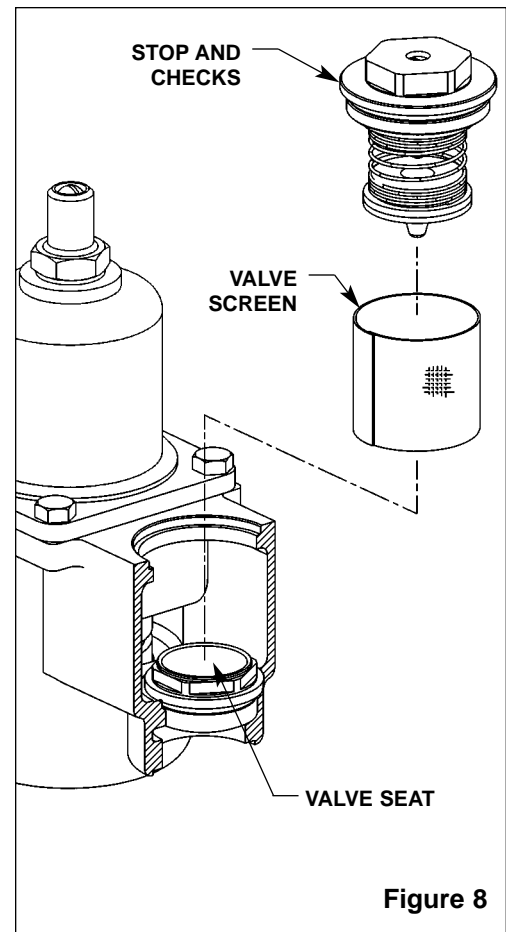

## S59-3200 Parts Breakdown and Service Kits

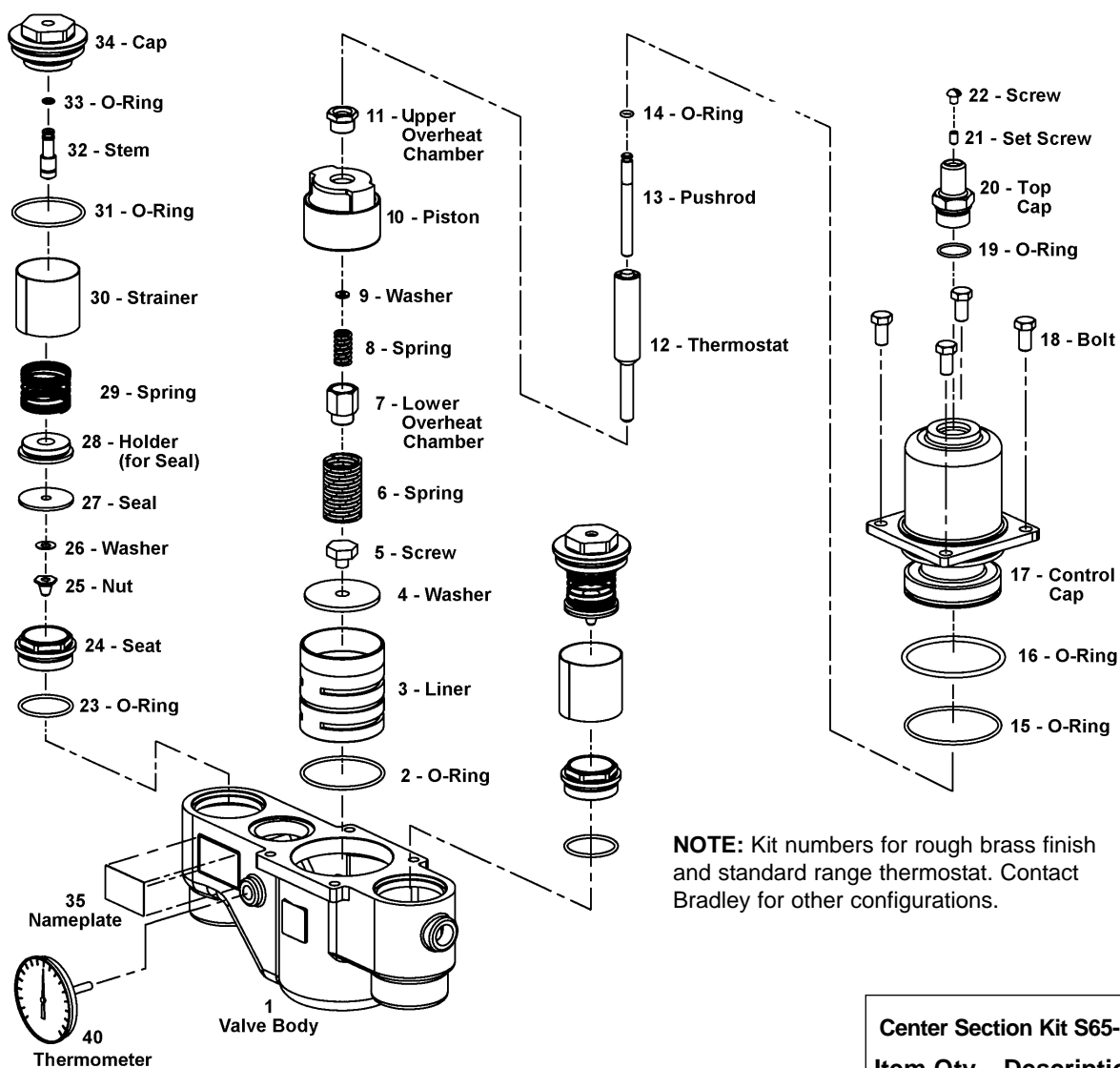

**NOTE:** Kit numbers for rough brass finish and standard range thermostat. Contact Bradley for other configurations.

### Thermostat Kit S65-194

Item	Qty.	Description
12	1	Thermostat
14	1	O-Ring
19	1	O-Ring

### Washer/Seal Kit S65-321

Item	Qty.	Description
4	1	Washer
9	1	Washer
26	2	Washer
27	2	Seal

### Piston & Liner Kit S65-196

Item	Qty.	Description
2	1	O-Ring
3	1	Liner
4	1	Washer
5	1	Screw
6	1	Spring
7	1	Lower Chamber
8	1	Spring
9	1	Washer
10	1	Piston
11	1	Upper Chamber

### O-Ring Kit S65-195

Item	Qty.	Description
2	1	O-Ring
14	1	O-Ring
15	1	O-Ring
16	1	O-Ring
19	1	O-Ring
23	2	O-Ring
31	2	O-Ring
33	2	O-Ring

### Check/Stop Kit S65-190

Item	Qty.	Description
23	2	O-Ring
24	2	Seat
25	2	Nut
26	2	Washer
27	2	Seal
28	2	Holder (for Seal)
29	2	Spring
30	2	Strainer
31	2	O-Ring
32	2	Stem
33	2	O-Ring
34	2	Cap

### Center Section Kit S65-302

Item	Qty.	Description
2	1	O-Ring
3	1	Liner
4	1	Washer
5	1	Screw
6	1	Spring
7	1	Lower Overheat Chamber
8	1	Spring
9	1	Washer
10	1	Piston
11	1	Upper Overheat Chamber
12	1	Thermostat
13	1	Pushrod
14	1	O-Ring
15	1	O-Ring
16	1	O-Ring
17	1	Control Cap
18	4	Bolt
19	1	O-Ring
20	1	Top Cap
21	1	Set Screw
22	1	Screw